

8681 Control Unit - D4

Control Unit for D4 series valves

FORM NO.: H342989 REVISION: GB-4

READ AND UNDERSTAND THIS MANUAL PRIOR TO OPERATING OR SERVICING THIS PRODUCT.



Triplex Sales
1-847-839-8442
www.triplexsales.com





8681 Control Unit - D4

CONTENTS

1.	OPERATING INSTRUCTIONS.....	8
1.1.	Symbols	8
1.2.	Definition of the term: “device”	8
2.	SAFETY INSTRUCTIONS	9
2.1.	Authorized Use.....	9
2.2.	Basic Safety Instructions	9
2.3.	Warranty.....	10
3.	SYSTEM DESCRIPTION	11
3.1.	Intended application area.....	11
3.2.	General description	11
3.3.	Functions / options / designs	12
3.3.1.	Structure of the 8681 Control Unit - D4	12
3.3.2.	External position sensor (housing)	13
3.3.3.	Fluid diagram	14
3.3.4.	Pneumatic interfaces	15
3.3.5.	Magnetic and mechanical manual control	15
3.3.6.	Position sensors	15
3.3.7.	Other features	16
4.	TECHNICAL DATA.....	17
4.1.	Operating conditions	17
4.2.	Conformity with the following standards	17
4.3.	Type label	18
4.4.	Dimensions / mechanical data	19
4.5.	Pneumatic data	20
4.6.	Data of position sensors	21
4.6.1.	Internal inductive position sensor	21
4.6.2.	External inductive position sensor	21



4.7.	Factory settings in the firmware	23
4.7.1.	Feedback fields (tolerance band) of the position sensors	23
4.7.2.	Changes to the factory settings for the feedback fields	23
4.7.3.	Service / maintenance notification (maintenance request)	24
4.7.4.	Magnetic manual control function	24
4.8.	Resetting the device (Device Reset)	25
5.	ASSEMBLY	26
5.1.	Safety instructions	26
5.2.	Assembly 8681 Control Unit - D4 on process valve	26
5.3.	Assembly sequences	28
5.4.	Realignment of the 8681 Control Unit - D4	29
5.5.	Selection of the process valve type (D4 series)	30
5.6.	Assembly of the pneumatic and electrical connections	31
5.7.	Recommended auxiliary materials	31
6.	OPENING AND CLOSING THE HOUSING	32
6.1.	Safety instructions	32
6.2.	Opening and closing the housing	32
6.2.1.	Opening the housing of the device	32
6.2.2.	Closing the housing of the device	33
7.	PNEUMATIC INSTALLATION	34
7.1.	Safety instructions	34
7.2.	Pneumatic connection of 8681 Control Unit - D4	34
7.3.	Flow restriction function of the pilot valves	35
8.	24 V DC - DESIGN	37
8.1.	Electrical connection	37
8.2.	Electrical data	37
8.3.	Design aid	38
8.4.	Safety instructions	39
8.5.	Electrical installation / start-up	39
8.6.	Logic tables for the valve D4 series	40



8.6.1.	Logic tables for SPX D4:	40
8.6.2.	Logic tables for SPX DA4	41
8.6.3.	Logic tables for SPX D4SL	41
8.6.4.	Logic tables for SPX D4PMO	41
9.	AS INTERFACE - DESIGN	43
9.1.	Definition	43
9.2.	Electrical connection for AS interface	43
9.3.	Number of connectable Control Units - D4	44
9.4.	Maximum length of the bus line	44
9.5.	Electrical data	45
9.6.	Design aid	47
9.7.	Safety instructions	48
9.8.	Electrical installation of the AS interface	48
9.9.	Programming data	50
9.9.1.	Programming data table	50
9.9.2.	Logic tables for the valve D4 series	50
10.	DEVICENET - DESIGN	53
10.1.	Definition	53
10.2.	DeviceNet specification	53
10.2.1.	Total line length and maximum line length according to DeviceNet specification	54
10.2.2.	Drop line length	54
10.3.	Electrical connection	54
10.4.	Electrical data	55
10.5.	Safety position if the bus fails	55
10.6.	Design aid	56
10.7.	Safety instructions	57
10.8.	Electrical installation - DeviceNet	57
10.9.	Network topology of a DeviceNet system	59
10.10.	Configuration of the DeviceNet address/ baud rate	59
10.10.1.	Setting of the DeviceNet address	60
10.10.2.	Setting the baud rate	61



10.11. Configuration of the process data.....	61
10.11.1. Static input assembly	61
10.11.2. Static output assembly.....	62
10.11.3. Logic tables for the valve D4 series.....	62
10.12. Configuration of the device	66
10.12.1. Configuration of the safety position of pilot valves during a bus error	66
10.12.2. Configuration example	66
10.12.3. EDS description	67
10.13. Display of the status LEDs in the event of a bus error.....	68
10.13.1. Status of the device status LED "Modules"	68
10.13.2. State of bus status LED "Network"	69
11. POSITION MEASURING SYSTEM / INDUCTIVE POSITION SENSORS	70
11.1. Operating principle of the position measuring system.....	70
11.2. Stroke range / feedback signals	70
12. TEACH PROCEDURE	71
12.1. Teach buttons / Teach functions	71
12.2. Autotune function	71
12.2.1. Autotune mode / Autotune function.....	71
12.2.2. Autotune function process	72
12.2.3. Autotune reset (Teach reset)	73
12.3. Manual teach procedure.....	73
13. LED COLOUR ASSIGNMENTS	75
13.1. Setting the colour combinations	75
13.2. Blinking pattern & fault signaling.....	76
14. SERVICE MODE / MANUAL CONTROL	77
14.1. Magnetic manual control.....	77
14.2. Mechanical manual control.....	78
15. MAINTENANCE / TROUBLESHOOTING	79
15.1. Safety instructions.....	79
15.2. Safety positions	80



15.3. Maintenance / service	80
15.4. Cleaning	81
15.5. Malfunctions	81
16. REPLACEMENT OF COMPONENTS AND MODULES	83
16.1. Safety instructions	83
16.2. Changing the electronic module	84
16.3. Changing the valves (Type 6524).....	85
16.4. Changing the internal position sensor	86
16.5. Spare parts	89
17. SHUTDOWN	91
17.1. Safety instructions	91
17.2. Dismantling the 8681 Control Unit - D4.....	91
18. PACKAGING AND TRANSPORT	92
19. STORAGE.....	92
20. DISPOSAL	92
21. APPENDIX - EDS DESCRIPTION	93



1. OPERATING INSTRUCTIONS

The operating instructions describe the entire life cycle of the device. Keep these instructions in a location which is easily accessible to every user, and make these instructions available to every new owner of the device.



WARNING!

The operating instructions contain important safety information!

- ▶ Carefully read these instructions.
- ▶ Observe in particular the safety instructions, intended use and operating conditions.
- ▶ Persons, who work on the device, must read and understand these instructions.

1.1. Symbols



DANGER!

Warns of an immediate danger!

- ▶ Failure to observe the warning will result in a fatal or serious injury.



WARNING!

Warns of a potentially dangerous situation!

- ▶ Failure to observe the warning may result in serious injuries or death.



CAUTION!

Warns of a possible danger!

- ▶ Failure to observe this warning may result in a moderate or minor injury.

NOTE!

Warns of damage to property!

- ▶ Failure to observe the warning may result in damage to the device or the equipment.



Important additional information, tips and recommendations

- ▶ Designates an instruction for risk prevention.
- Designates a procedure which you must carry out.

1.2. Definition of the term: “device”

The term “device” used in this manual generally denotes the “8681 Control Unit - D4” for process valves D4 series.



2. SAFETY INSTRUCTIONS

2.1. Authorized Use

Incorrect use of the device may be dangerous to people, nearby equipment and the environment.

The 8681 Control Unit - D4 is designed for use as a control unit for pneumatically actuated process valves and / or for recording their switching states.

- ▶ Use the device for its intended purpose only! Non-intended use of the device may be dangerous to people, nearby equipment and the environment.
- ▶ Use the device according to the authorized data, operating conditions and conditions of use specified in the contract documents and operating instructions. These are described in chapter [“4. Technical Data”](#).
- ▶ In view of the large number of application options, check and, if necessary, test prior to installation whether the device is suitable for the specific application case:
Should you have any questions, please contact the SPX Flow Service Center.
- ▶ Use the device only in conjunction with third-party devices and components recommended and authorized by the manufacturer.
- ▶ Any unauthorized reconstructions and changes to the device are prohibited for safety reasons.
- ▶ Correct transportation, correct storage and installation as well as careful operation and maintenance are essential for reliable and problem-free operation.
- ▶ For connecting the device, use line installations that do not cause any mechanical stresses.

2.2. Basic Safety Instructions

These safety instructions do not consider any contingencies or incidents which occur during installation, operation and maintenance.

The operator is responsible for observing the location-specific safety regulations, also with reference to the personnel.

DANGER!

Risk of electric shock!

- ▶ Before reaching into the system, switch off the power supply and secure it to prevent restarting!
- ▶ Observe applicable accident prevention and safety regulations for electrical equipment!

WARNING!

Danger – high pressure in the plant / at the device!

- ▶ Before loosening lines and valves, turn off the pressure and vent the lines.



WARNING!

General hazardous situations.

To prevent injuries:

- ▶ Operate the device only in perfect state and in consideration of the operating instructions.
- ▶ Observe the general rules of technology.
- ▶ Install the device according to the regulations applicable in the respective country.
- ▶ Only trained technicians may perform installation and maintenance work.
- ▶ Perform installation and maintenance with suitable tools only.
- ▶ Do not make any unauthorized internal or external changes to the device!
- ▶ Ensure that the system cannot be activated unintentionally.
- ▶ After the process is interrupted, restart in a controlled manner. Observe sequence: first connect electrical or pneumatic power supply, than charge the device with medium.

NOTE!

Electrostatic sensitive components/modules!

The device contains electronic components which react sensitively to electrostatic discharge (ESD). Contact with electrostatically charged persons or objects may be hazardous to these components. In the worst case scenario, they will be destroyed immediately or will fail after start-up.

- ▶ Observe the requirements in accordance with EN 61340-5-1 to minimize or avoid the possibility of damage caused by sudden electrostatic discharge!
- ▶ Also ensure that you do not touch electronic components when the supply voltage is on!

NOTE!

Risk of damage to property!

- ▶ Do not connect any mechanically rigid connection parts, in particular those with long lever arms, as such connections could generate torques that might damage the device.
- ▶ Do not supply the medium connections of the system with liquids or aggressive or flammable media!
- ▶ Do not subject the housing to mechanical loads (e.g. by placing objects on it or standing on it).
- ▶ Do not make any external changes to the housings of the device. Do not paint housing parts or screws.
- ▶ Only use compatible cleaning agents for cleaning the securely closed device and always rinse thoroughly with clean water.

2.3. Warranty

This document does not contain any warranty acceptance. We refer to our general terms of sale and delivery. Prerequisite for a guarantee is the correct use of the unit in compliance with the specified conditions of application.



Note! This warranty only applies to the device (8681 Control Unit - D4). No liability will be accepted for consequential damage of any kind arising from failure or malfunction of the device.



3. SYSTEM DESCRIPTION

3.1. Intended application area

The device has been designed for use as an actuator for pneumatically operated process valves D4 series and / or for recording the switching states of these.

3.2. General description

The device is used for actuating pneumatically operated process valves D4 series .

For process valve actuation, the 8681 Control Unit - D4 is equipped with up to three pilot valves.

For the recording and feedback of the process valve switching positions to a higher-level control, the device has been equipped with two contact-free position sensors which operate with up to 4 discrete, adjustable feedback signals.

The 8681 Control Unit - D4 is delivered with a connected external position sensor. The 8681 Control Unit - D4 and the process valve D4 series are interconnected via the housing containing the external position sensor.

This produces an integrated, compact and decentralized system of feedback, actuation and valve function. The following advantages over centralized solutions working with valve clusters are achieved:

- low installation expenditure
- easy start-up
- higher application-specific flexibility
- shorter switching times and less air consumption due to shorter distances between the pilot valves and the process valve. 1 or 3 solenoid valves (Type 6524) in the device serve as pilot valves.

Various pneumatic and electrical connection variants are available - described in the following chapters.

3.3. Functions / options / designs

3.3.1. Structure of the 8681 Control Unit - D4

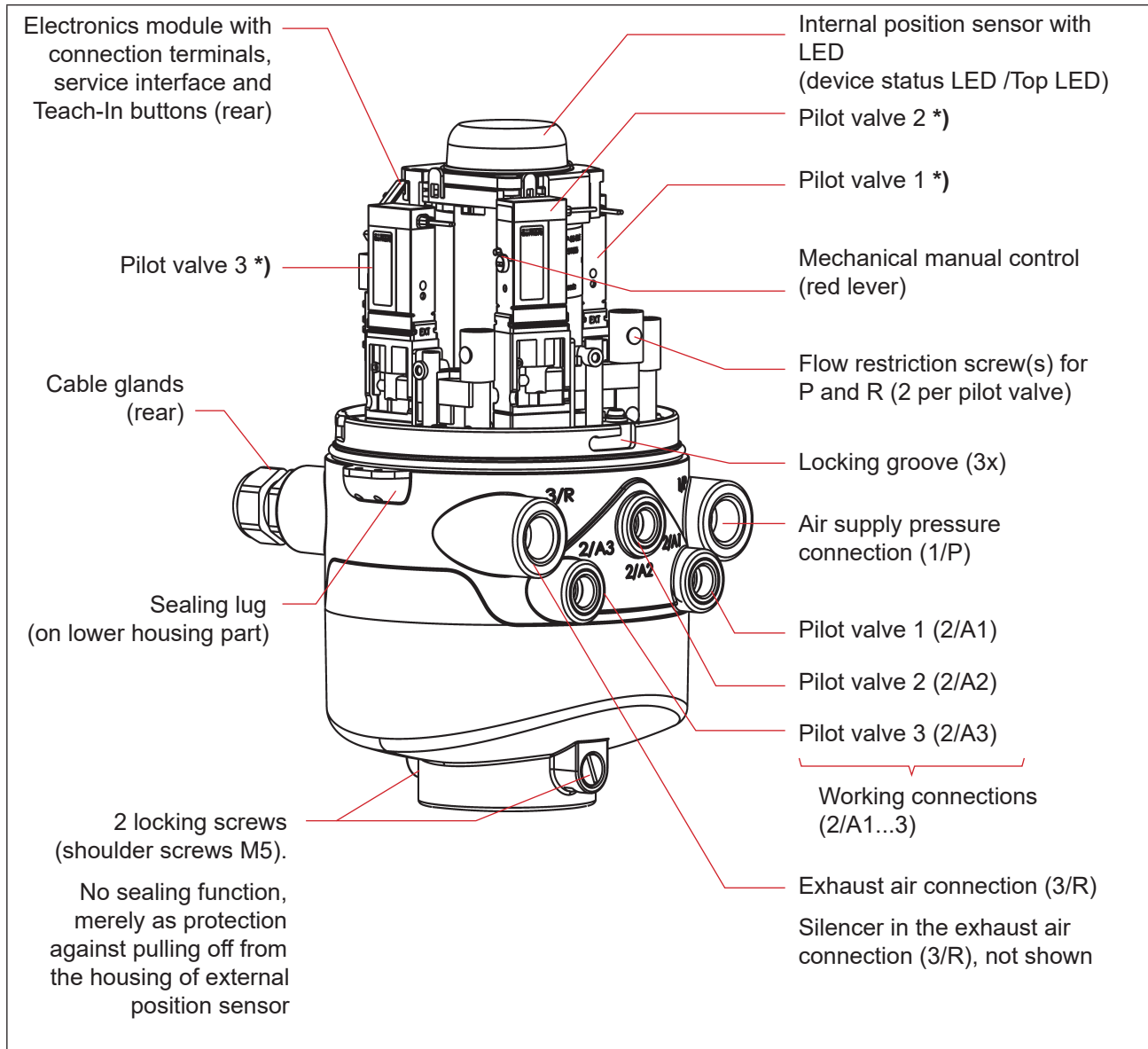

Fig. 1: General Structure of the 8681Control Unit - D4 (shown without external position sensor)

*) If a pilot valve is not present, the connection is sealed tightly with a cover plate.

3.3.2. External position sensor (housing)

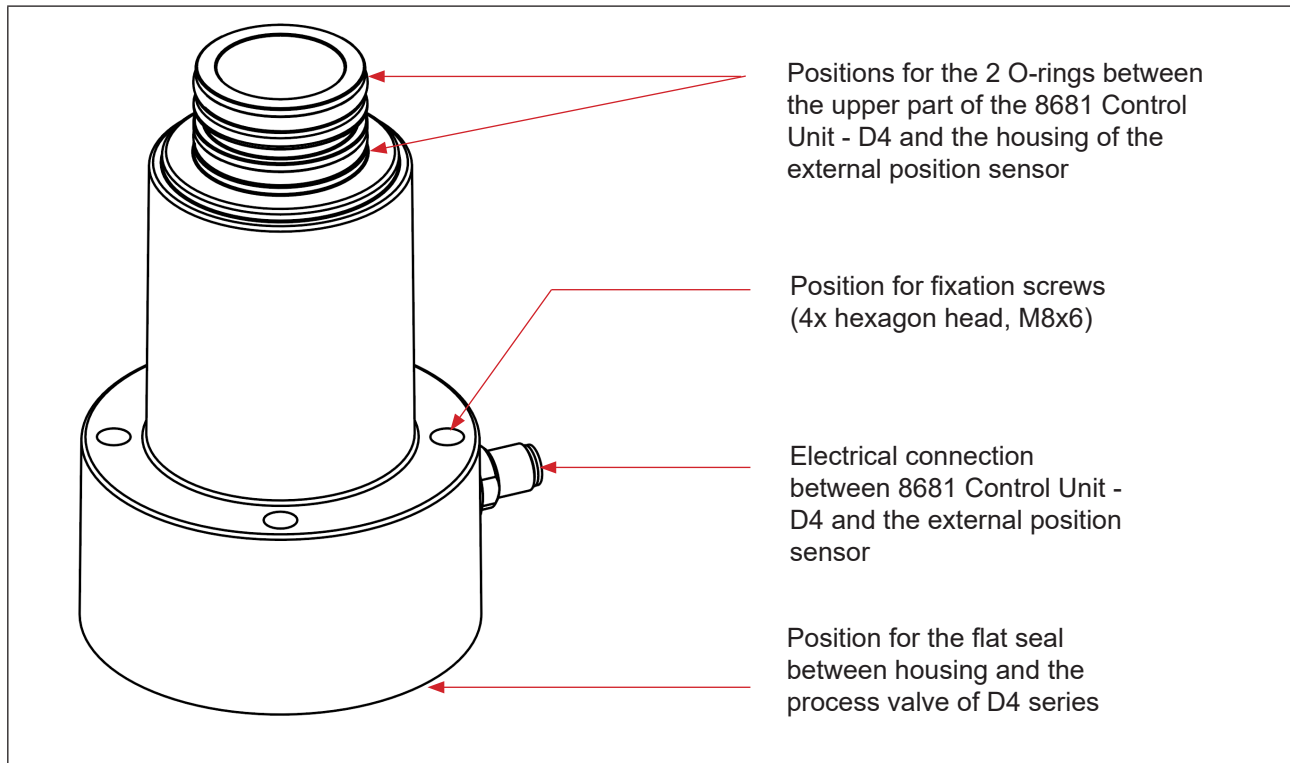

Fig. 2: External position sensor inside housing

3.3.3. Fluid diagram

Fluid diagram for the device (with restriction capability for each pilot valve Type 6524):

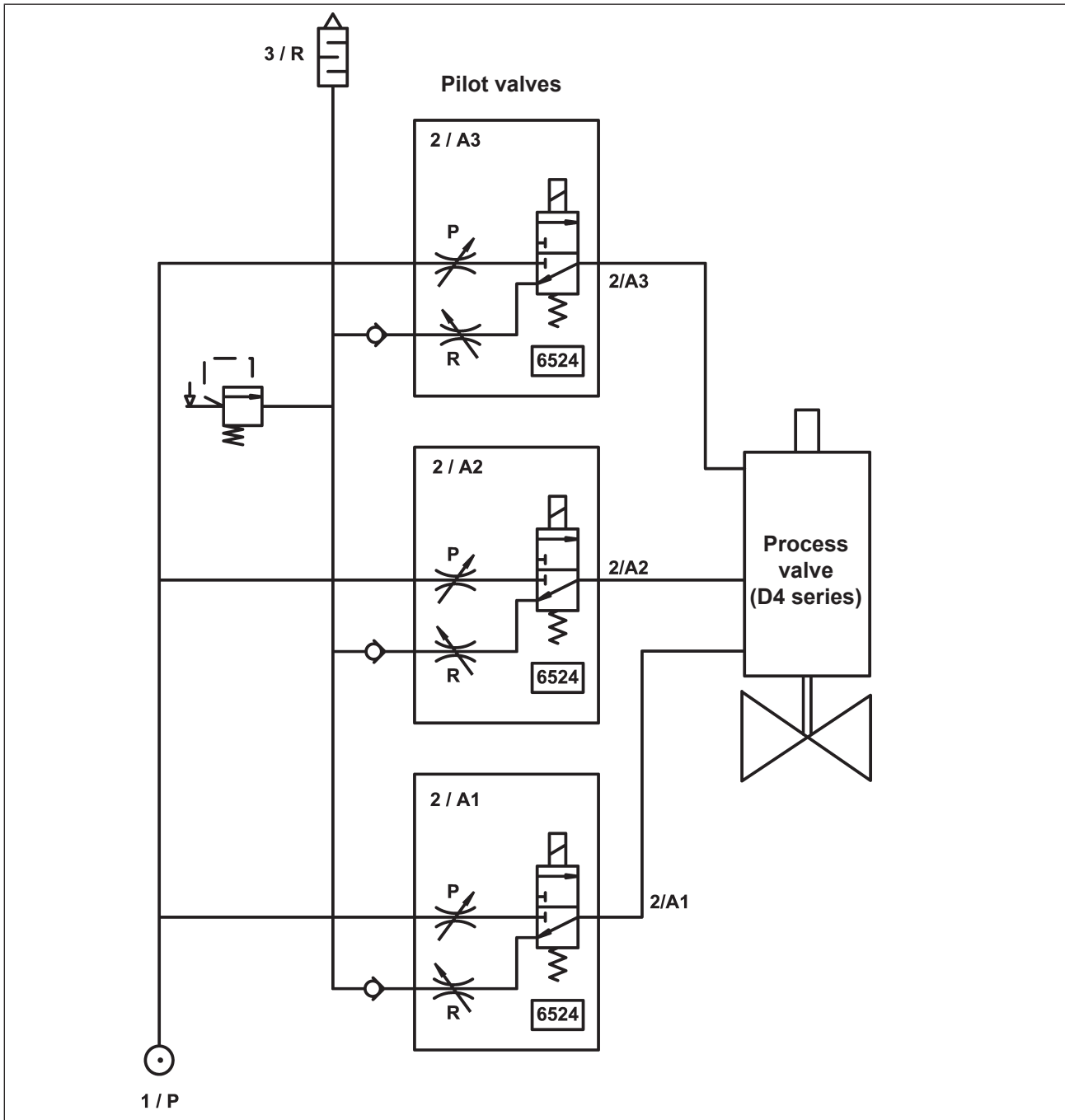

Fig. 3: Fluid diagram (variant with 3 pilot valves in the 8681 Control Unit - D4)

3.3.4. Pneumatic interfaces

- Intake & exhaust air connections (1/P, 3/R): G 1/4
Working connections (2/A1 ... 3): G 1/8
- Integrated non-return valves in the pilot valves' exhaust air duct
- Actuation of connection 2/A1 (pilot valve V1; normally the main stroke of the process valve) using the magnetic manual control (manual override) that is externally accessible.
- A special silencer with a high flow-rate capacity to connection 3/R is already mounted.
- The interior of the housing is protected against excessive overpressure, for example due to leakages, by a pressure-relief valve with output into the joint exhaust air connection 3/R.

3.3.5. Magnetic and mechanical manual control

The 8681 Control Unit - D4 provides the following as standard:

- *Magnetic manual control (manual override):*
easily accessible from the outside, on the basis of encoded magnetic fields for pilot valve V1 (connection 2/A1) as well as
- *Mechanical manual control:*
on each equipped pilot valve, accessible only when the housing is open ([“Fig. 6”](#))

The magnetic manual control has the following advantages:

- the device does not need to be opened
- simple actuation tool for opening/closing pilot valve V1 (main stroke) - helpful for service/maintenance work on the process valve
- LED display for the "activated (magnetic) manual control" status = service mode (see chapters [“13. LED Colour Assignments”](#) and [“14. Service Mode / Manual Control”](#))



For a detailed description of the manual control, see chapter [“14. Service Mode / Manual Control”](#).

3.3.6. Position sensors

The switching positions of the process valve are reported to the higher-level control by feedback signals from two contact-free / inductive position sensors.

The connection to the device is done by means of a simple adaptation to the process valve's shaft. Details are described in chapters [“4.6. Data of position sensors”](#) on page 21 and [“11. Position Measuring System / Inductive Position Sensors”](#) on page 70.



3.3.7. Other features

- **Central optical position indicator (device status LED /Top LED) for showing the process valve switching positions:** positions and status information are generally indicated by 3 signal colours of the device status LED (Top LED)
- **Simple adaptation of the 8681 Control Unit - D4** to the shaft of the process valve D4 series
- **Simple determination of the valve and seat state** via Autotune function of the position sensors (using three Teach buttons on the electronic module)
- The **capability of restricting the pilot valves** for the individual setting of the expansion and retraction rates of the process valve and the individual setting of the flow-rate of the working connections (see [“Fig. 6: Flow restriction screws and mechanical manual control of the pilot valves”](#) on page 20)
- **Energy efficient pilot valve actuation** by lowering the holding current during long-term operation

4. TECHNICAL DATA

4.1. Operating conditions

 **CAUTION!**

Risk of injury from overheating of the device.

Heating above the permitted temperature range can endanger people, the device and the environment.

▶ Do not expose the device to any mechanical or thermal loads that will exceed the limits described in the operating instructions.

Ambient temperature: -10 ... +55 °C

Degree of protection:

Standard version:

IP65 / IP67 according to EN 60529
(only if cables, plugs and sockets have been connected correctly, the hood has been sealed correctly and the adaptation to the process valve was done correctly)



IP69K according to IEC 40050-9
(Housing seal with connected exhaust air line instead of silencer and ideally closed cable glands confirmed through IP69K Standard testing)

4.2. Conformity with the following standards

The 8681 Control Unit - D4 conforms to the EU Directives according to the EU Declaration of Conformity.

The applied standards, which are used to demonstrate compliance with the EU Directives, are listed in the EU Declaration of Conformity and/or the EU type test certificate. These are available from the manufacturer.

The specifications on the respective type label indicate the technical data and approvals applicable to the respective device. The symbols on the type label mean:

Symbols on the type label:	
	Device complies with European standards according to EC Declaration of Conformity
	<p>UL approval for USA and Canada</p> <p>UL 61010-1 AND CSA C22.2 NO. 61010-1</p> <p>Restrictions: Application area: 0 to +55°C, Indoor use, power supply with class-2 power supply unit</p>

4.3. Type label



	8681 CU-D4 DevNet 3 pilot valves P 2,5 - 8 bar, Tamb -10 .. +55°C	Device description Device design *)
	S/N 0	Permitted pressure range / ambient temperature range
	H342336	Serial number S/N (CE mark)
	manufactured by bürkert	ID number coded date of manufacture manufacturer
		

Fig. 4: Type label for the 8681 Control Unit - D4

*) Device design:
 Type of communication (24 V DC, AS-i, DevNet);
 (possibly operating voltage) and number of pilot valves

4.4. Dimensions / mechanical data

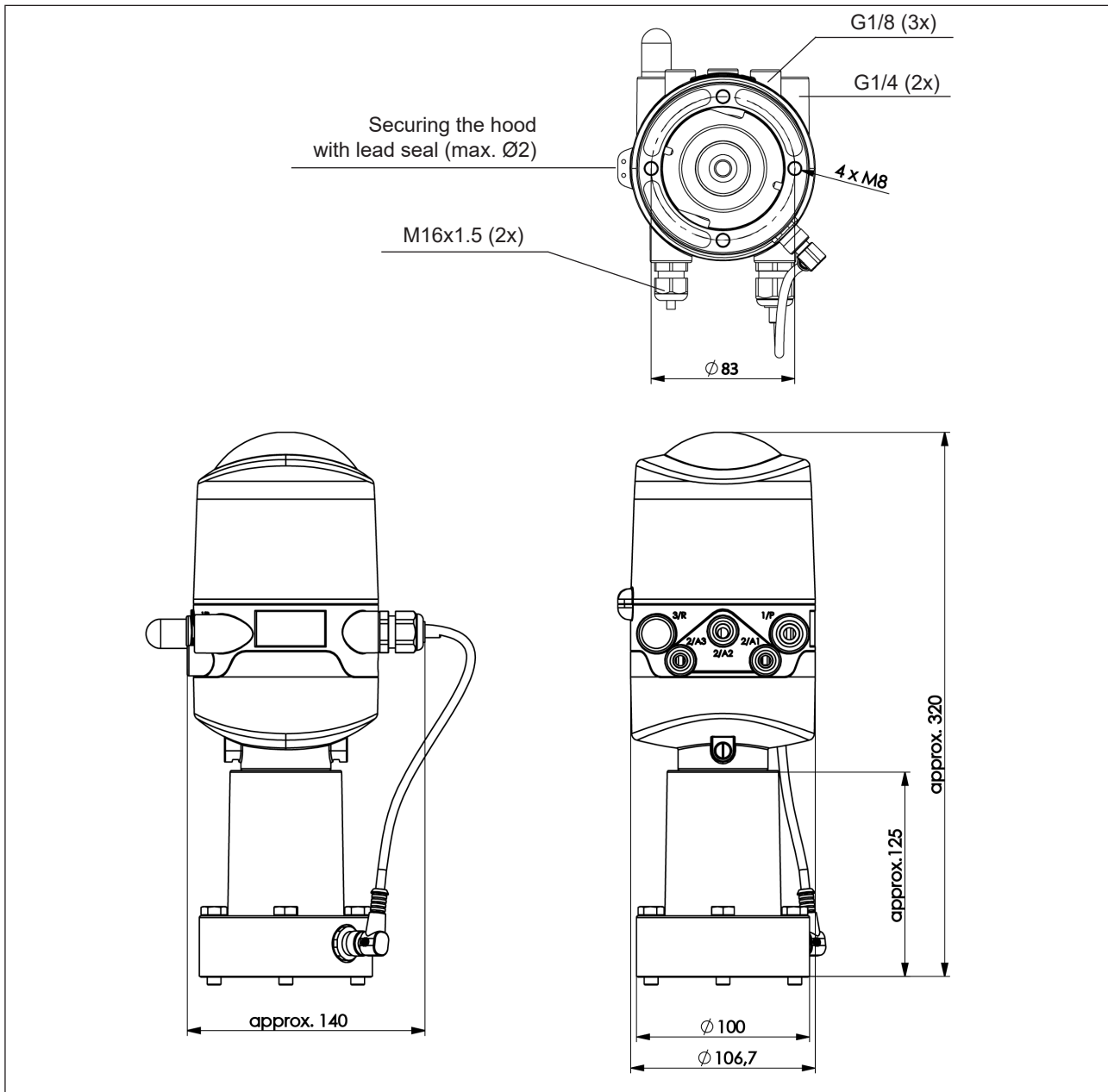

Fig. 5: Dimensional drawing (for models with 1 or 3 pilot valves)

Weight:	approx. 1 kg
Housing material:	exterior: PA, PC, PPO, VA inside: ABS, PA, PMMA
Sealing material:	exterior: CR, EPDM inside: EPDM, FKM, NBR

4.5. Pneumatic data

Control medium:	Air, neutral gases Quality classes in accordance with ISO 8573-1 (5 µm filter recommended)
Dust content	Quality class 7: max. particle size 40 µm, max. particle density 10 mg/m ³
Water content	Quality class 3: max. pressure dew point -20 °C or min. 10 °C below the lowest operating temperature
Oil content	Quality class X: max. 25 mg/m ³
Temperature range of compressed air:	-10 ... +50 °C = 14 ... 122 °F
Pressure range:	2.5 ... 8 bar = 36 ... 116 psi
Air rate pilot valve:	Q _{Nn} = approx. 110 l _N /min (for ventilation and deaeration, aeration) (110 l _N /min - supplied state 200 l _N /min - maximum typical flow rate) (Q _{Nn} value according to definition when pressure drops from 7 to 6 bar absolute at +20 °C)
Connections:	Intake and exhaust air connection (1/P, 3/R): G1/4 Working connections (2/A1...3): G1/8

Intake and exhaust air setting at pilot valves with flow restriction screws:

The intake and exhaust air can be set separately for each pilot valve using flow restriction screws, in order to be able to affect the expansion and retraction rates of the process valve (see figure below).

For details see chapter [“7.3. Flow restriction function of the pilot valves”](#) on page 35

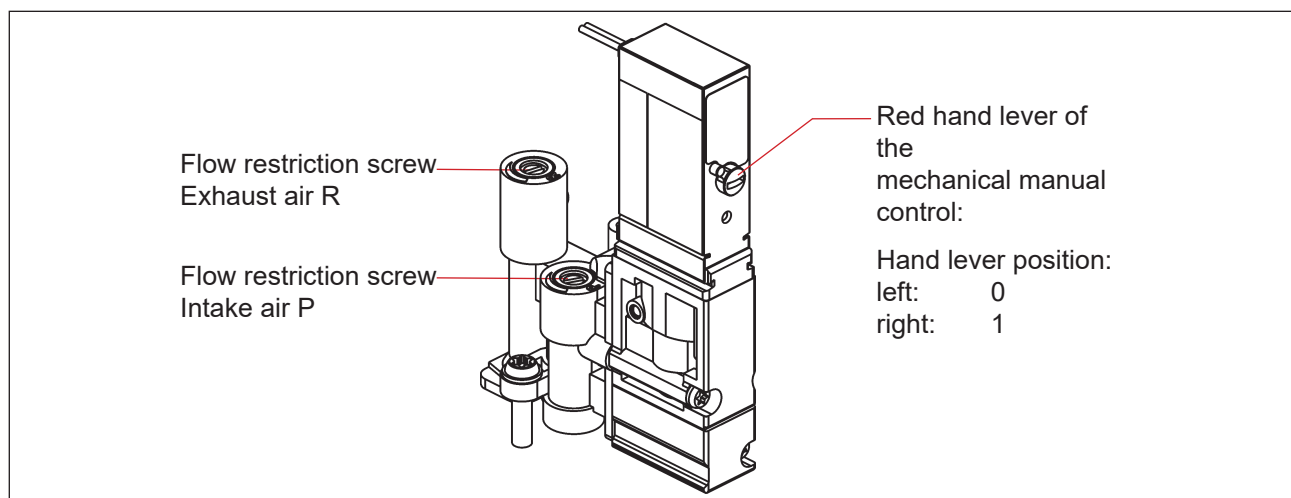

Fig. 6: Flow restriction screws and mechanical manual control of the pilot valves



4.6. Data of position sensors

The device contains two combined (but independent) analog linear inductive position sensors with 4 switching points (resulting in valve states: process valve closed, process valve open, upper seat lift, lower seat lift).

4.6.1. Internal inductive position sensor

The **internal inductive position sensor** of the device is used for the target positions **S3** and **S4**.

Stroke range (measuring range):	0 ... 80 mm
Resolution:	≤ 0.1 mm
Total error:	± 0.5 mm - when using the delivered target and shaft extension (fault refers to the reproducibility of a taught position)
Target material:	ferromagnetic material (stainless steel 1.4021)
Shaft (extension) material (*):	non-ferromagnetic material (see note (*) below)

The "[Fig. 7](#)" shows the relationship between the device, shaft with internal and external target.

4.6.2. External inductive position sensor

The **external inductive position sensor** of the device is used for the target positions **S1** and **S2**.

Stroke range:	0 ... 40 mm (max. usable measuring range)
Resolution:	≤ 0.1 mm
Total error:	± 0.5 mm - when using the delivered target (fault refers to the reproducibility of a taught position)
Target material:	ferromagnetic material (stainless steel 1.4021)
Shaft material (*):	non-ferromagnetic material (see note (*) below)

The "[Fig. 7](#)" shows the relationship between the device, shaft with internal and external target.

(*) *The fastening materials* for the targets and the shaft (extension) as well as *the shaft (extension) themselves* may not be made of material with very good electrical conductivity (e.g. copper, aluminum) or of ferromagnetic material.

Stainless steel without ferromagnetic properties is suitable (if necessary, check after

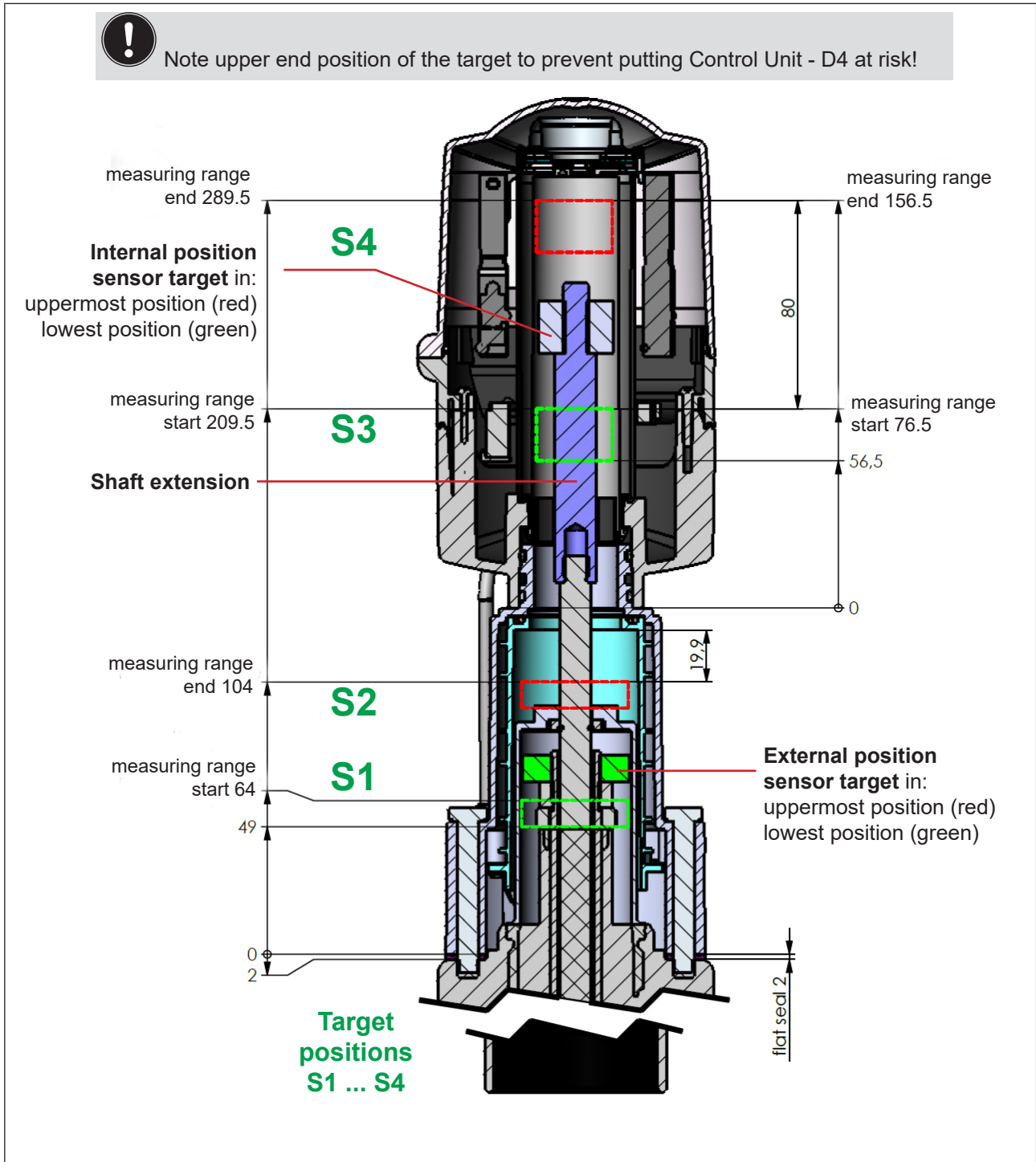

Fig. 7: Sectional view of device and shaft with both targets of internal and external position sensor

4.7. Factory settings in the firmware

The device is supplied with the firmware factory settings as listed below.

4.7.1. Feedback fields (tolerance band) of the position sensors

A feedback field or tolerance band is the area within which a valve position is reported back.

Signal of the target position		Feedback field (positive values)		Feedback field (negative values)	
		Factory setting [mm]	Adjustment range [mm]	Factory setting [mm]	Adjustment range [mm]
external sensor	S1	+ 1.00	+ 10.00 ... + 0.50	- 1.00	- 0.50 ... - 10.00
	S2	+ 1.00	+ 10.00 ... + 0.50	- 1.00	- 0.50 ... - 10.00
internal sensor	S3	+ 1.00	+ 10.00 ... + 0.50	- 1.00	- 0.50 ... - 10.00
	S4	+ 1.00	+ 10.00 ... + 0.50	- 3.00	- 0.50 ... - 10.00

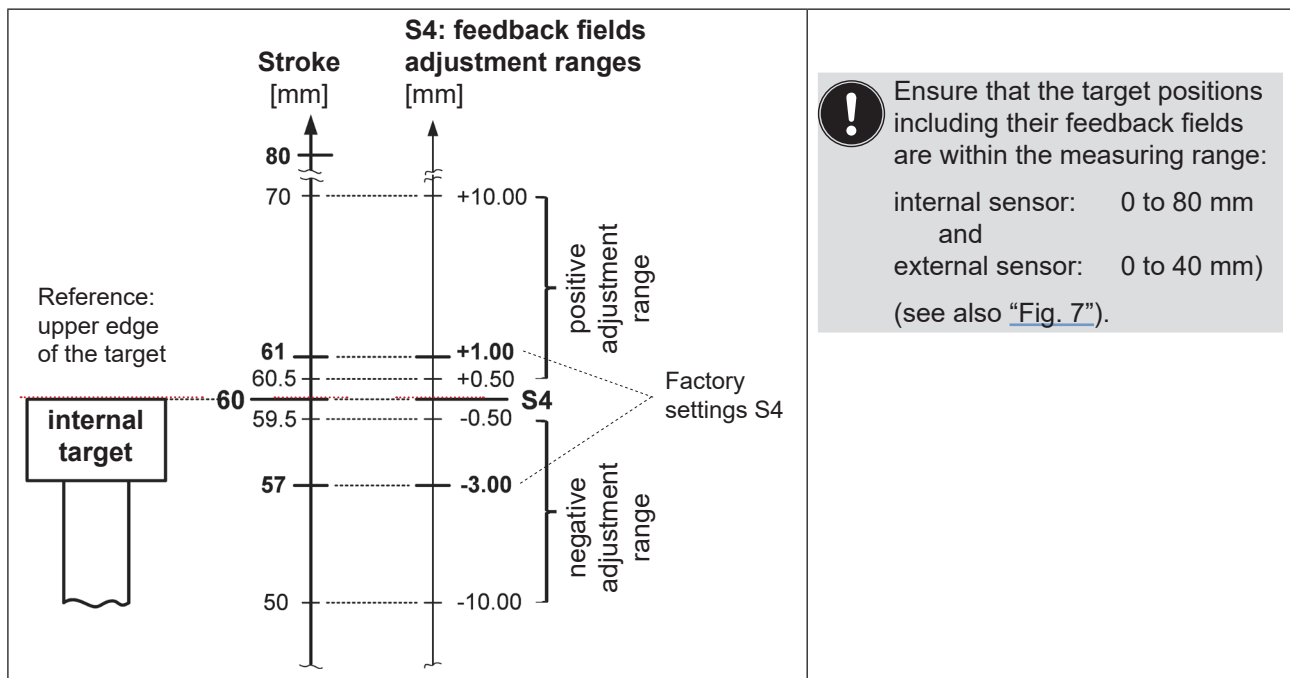

Fig. 8: Schematic diagram (not to scale) of the feedback fields, for example for target position S4

4.7.2. Changes to the factory settings for the feedback fields

Changes to the factory settings for the feedback fields are possible using the PC service program for the device (for designs: AS-i, DeviceNet, 24 V DC).

4.7.3. Service / maintenance notification (maintenance request)

Factory setting for the "Service/maintenance notification" function: **not active**.

When Service/maintenance notification is activated, this is indicated by a special blinking pattern - see chapter "13.2. Blinking pattern & fault signaling" on page 76.

The Service/maintenance notification is used to observe predefined maintenance intervals which should occur either after an adjustable number of switching cycles or when a certain time has elapsed. The PC service program is used to adjust the service/maintenance interval (number of days or switching cycles) as well as activation/deactivation of the "Service/maintenance notification" function.

Connection to the PC is via the Service interface - see "Fig. 9: Location of the Service interface on different electronic modules". Details on the "Service" menu option are described in the "PC service program" manual.

Feedback, indicating that a service / maintenance is required (Service/maintenance notification), occurs when a Service/maintenance notification is activated after the following counter readings:

Counter readings (service interval)	Factory setting	Adjustment range
Switching cycle counter V1	10 000	(1 ... 255) x 1000
Switching cycle counter V2	50 000	(1 ... 255) x 1000
Switching cycle counter V3	50 000	(1 ... 255) x 1000
Operating duration	365 days	1 ... 65 535 days

The resettable operating hour and switching cycle counters are reset to "0" when a Device Reset occurs.

4.7.4. Magnetic manual control function

Factory setting for magnetic manual operation: **active**.

Deactivation is possible using the PC service program, the connection to the PC is via the Service interface - see "Fig. 9". Details are described in the "PC service program" software manual under the "SYSTEM/Start-up" menu option.

Compare also chapter "14.1. Magnetic manual control".

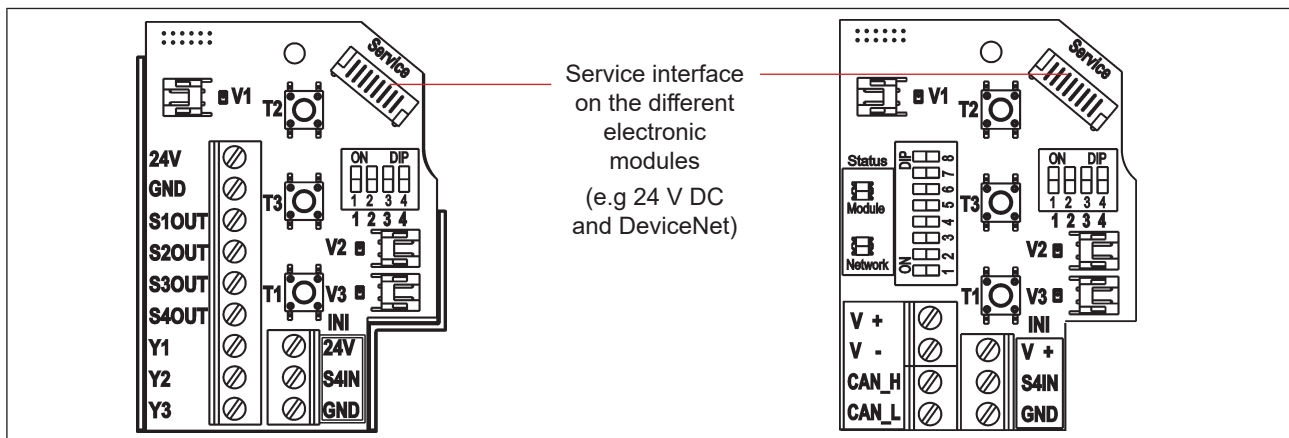

Fig. 9: Location of the Service interface on different electronic modules

4.8. Resetting the device (Device Reset)

A restricted reset of the device to factory settings can be performed:

- using the PC service program (see the "PC service program" software manual) or
- directly at the device.

Device Reset Procedure (directly at the device):

- Actuate simultaneously T1 + T2 + T3 (approx. 2.5 s long) to access the "Device Reset" **mode** – for the corresponding feedback colour and blinking pattern see chapter "[13. LED Colour Assignments](#)".
If the device is not reset 10 s after switching to the "Device Reset" mode, this mode is automatically left.
- Actuate simultaneously T1 + T2 + T3 again (approx. 2.5 s long) – this will reset the device **function** for real. For the corresponding feedback colour and blinking pattern see chapter "[13. LED Colour Assignments](#)".

Device Reset resets the following values to the factory settings:

- Target positions S1...S4 all target positions "not taught"
- Feedback fields from S1...S4 (see chapter "[4.7.1](#)" on page 23)
- Resettable switching cycle counters V1...V3 (see chapter "[4.7.3](#)" on page 24)
- Resettable operating duration (see chapter "[4.7.3](#)" on page 24)
- Service intervals switching cycles V1...V3 (see chapter "[4.7.3](#)" on page 24)
- Service interval operating duration (see chapter "[4.7.3](#)" on page 24)
- Service/maintenance notification (signaling of elapsed maintenance intervals) inactive (see chapter "[4.7.3](#)" on page 24)
- Manual control function active (see chapter "[4.7.4](#)" on page 24)

Device Reset does not reset the following values (i.a.):

- all hardware configured values (i.e. set via DIP switches)
- Switching cycle counter Total V1...V3
- Operating duration Total
- AS-i address (see chapter "[9.9](#)" on page 50)
- AS-i profile
- DeviceNet Input Assembly (see chapter "[10.11.1](#)" on page 61)
- DeviceNet settings for (process) valve safety mode and position (see chapter "[10.12](#)" on page 66)

5. ASSEMBLY

5.1. Safety instructions

DANGER!

Risk of injury due to electric shock!

- ▶ Before reaching into the system, switch off the power supply and secure it to prevent restarting!
- ▶ Observe applicable accident prevention and safety regulations for electrical equipment!

WARNING!

Risk of injury due to high pressure in the system!

- ▶ Before loosening lines and valves, turn off the pressure and vent the lines.

Risk of injury due to unintentional activation of the system and uncontrolled restart!

- ▶ Secure system against unintentional activation; following assembly, ensure a controlled restart.

CAUTION!

Risk of injury due to improper assembly!

- ▶ Assembly may only be carried out by trained technicians and with the appropriate tools!

5.2. Assembly 8681 Control Unit - D4 on process valve

The device is delivered with a connected external position sensor with its housing.

The device can be installed in any installation position, preferably with the hood face up.

The device should be installed such that layers of dust thicker than 5 mm cannot form; meaning that such should be ensured through correspondingly regular cleaning.

NOTE!

Risk of injury due to improper assembly!

- ▶ Do not improperly stress the device.
- ▶ Do not apply any leverage effect on the head and do not climb on it.
- ▶ When sealing the housing from the outside to the inside, make sure that the inflow of cleaning agent is considered and that the actuator space of the process valve towards the device is sealed.

Before installing the 8681 Control Unit - D4 onto a process valve D4 series, the delivered target for the external position sensor has to be screwed on the shaft of the process valve D4 series. For the assembly procedure see [“5.3. Assembly sequences”](#) and compare [“Fig. 10”](#).

All other necessary parts for mounting on process valves D4 series are included with deliveries.

The delivered non-ferromagnetic shaft extension and both ferromagnetic targets for internal and external position sensor comply with the specifications regarding material and dimensional accuracy – see chapter [“4.6. Data of position sensors”](#) or also [“Fig. 10”](#).

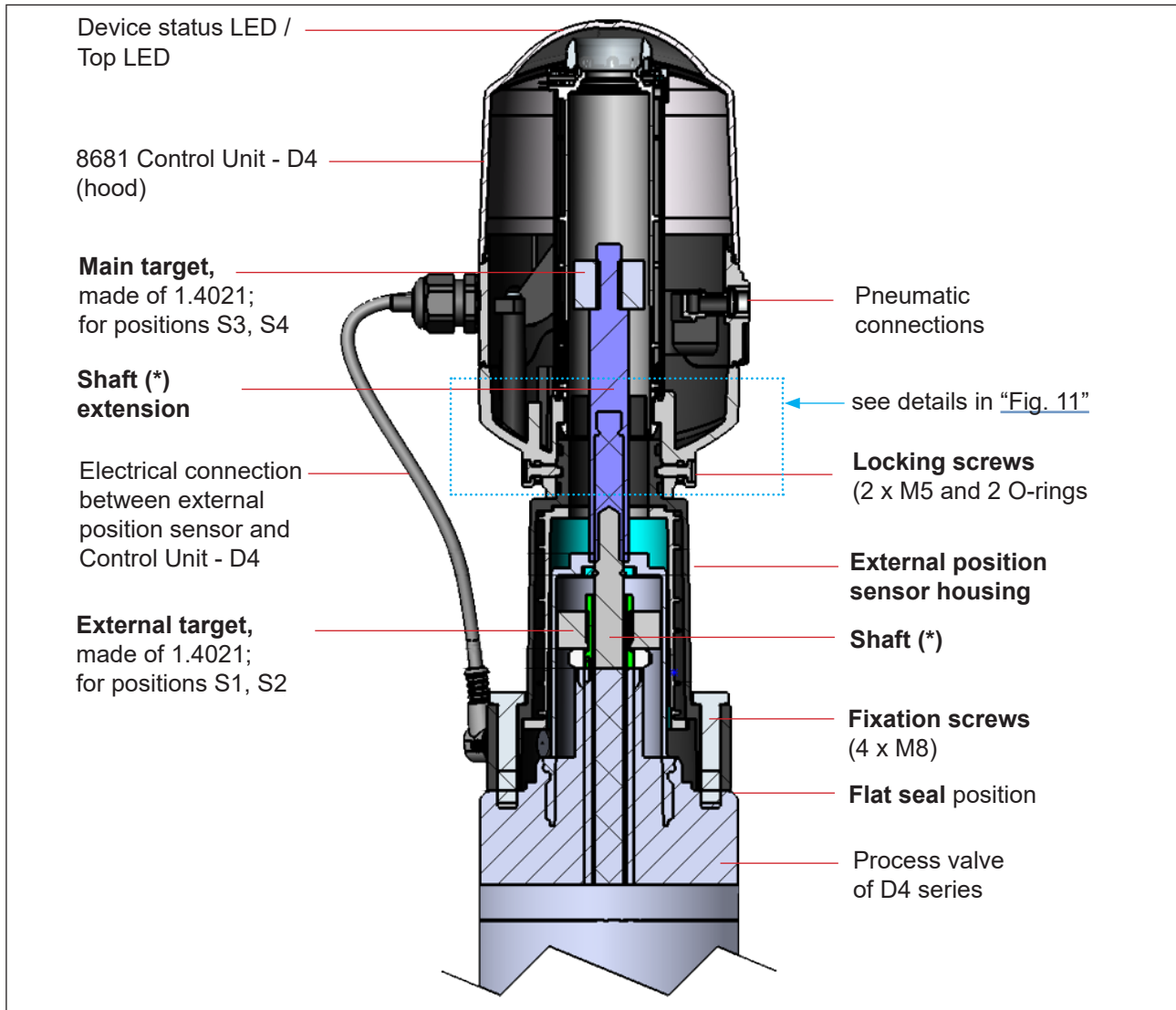

Fig. 10: Principle layout of the connection of the device and process valve D4 series

(*) The fastening materials for the targets and the shaft (extension) as well as the shaft (extension) themselves may not be made of material with very good electrical conductivity (e.g. copper, aluminum) or of ferromagnetic material. Stainless steel without ferromagnetic properties is suitable (if necessary, check after machining).

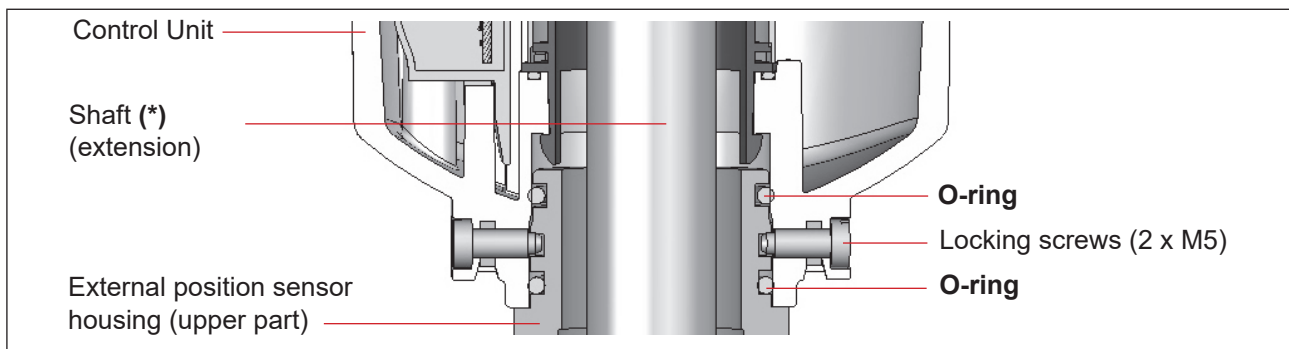



Fig. 11: Detail of the connection of 8681 Control Unit - D4 and the external position sensor housing

- 
 • To ensure the proper function of the position measuring system, the axial deviation of both position sensors must be less than ± 0.1 mm to the valve shaft when mounted!
- Use original manufacturers parts exclusively.
- Prior to assembling the device onto the process valve, lightly grease the flat seal and the O-rings with a silicone grease (see “5.7”).

For details, see also chapter “4.6. Data of position sensors”.

5.3. Assembly sequences



The delivered accessories consist of:

- 4 fixation screws M8
- shaft extension with target for internal position sensor
- target for external position sensor
- flat seal (EPDM)

Fig. 12: Delivered accessories

Procedure for mounting the external target:

→ First assemble the delivered external target on the process valve D4 series as shown in steps 1 to 6 below:







1.	2.	3.	4.	5.	6.
					
remove the black top capsule off the process valve	remove the washer		screw on the delivered target on the process valve shaft	re-assemble the washer again	re-assemble the black top capsule again

Fig. 13: Assembly sequence for mounting the external target on the process valve D4 series

Procedure for mounting the 8681 Control Unit - D4:

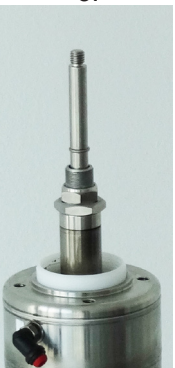
→ Then perform next steps 7 to 10 (see below) and subsequently make all required connections:

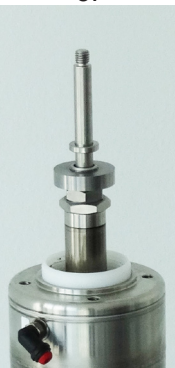



<p>7.</p> 	<p>8.</p> 	<p>9.</p> 	<p>10.</p> 	
<p>process valve D4 series with the mounted delivered target</p>	<p>assemble the delivered shaft extension with the target for the internal position sensor</p>	<p>put the flat seal in correct position</p>	<p>put the device as delivered over the target on the process valve</p>	<p>Fix the device on the process valve with the 4 fixation screws M8 (recommended tightening torque: 8 Nm)</p>

Fig. 14: Assembly sequence for 8681 Control Unit - D4

→ For suitable position for hoses and cables, realign/rotate the upper part of the device as described in chapter [“5.4. Realignment of the 8681 Control Unit - D4”](#)

→ Connect the hoses as described in chapter [“7. Pneumatic Installation”](#) on page 34

→ Perform the electrical connections considering the necessary information given in the linked chapters of the respective device design:

[“8. 24 V DC - Design”](#) on page 37

[“9. AS Interface - Design”](#) on page 43

[“10. DeviceNet - Design”](#) on page 53

[“11. Position Measuring System / Inductive Position Sensors”](#) on page 70

→ Set the valve type - described in chapter [“5.5. Selection of the process valve type \(D4 series\)”](#)

5.4. Realignment of the 8681 Control Unit - D4

If necessary, the device can be realigned/rotated 360°, in particular if properly accessible installation of the pneumatic supply lines is not possible due to spatial conditions. This might also be required for operational aspects (accessibility of the manual control) and because of electrical connection possibilities.

The axial fastening is done by two locking screws (shoulder screws M5), which engage in the middle groove of the external position sensor housing (protection against pulling off).

Procedure:

→ Loosen the locking screws (shoulder screws M5 – see “Fig. 11”) slightly until the underside of the screw head is flush with the auxiliary surface of the housing.

! The locking screw has been loosened sufficiently when the lower side of the screw head is flush with the auxiliary surface of the housing.

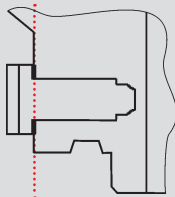

The locking screw is sufficiently tightened when the upper side of the screw head is flush with the auxiliary surface of the housing.

Tightening torque: max. 3.2 Nm

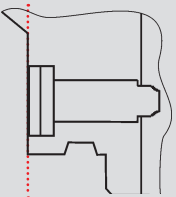

- Rotate the device until the desired alignment has been achieved.
- Secure it with locking screws again until the upper side of the screw head is flush with the auxiliary surface of the housing – tightening torque: max. 3.2 Nm.
The locking screws have **no sealing function**. The device is **not fixed in place** by the locking screws but is merely secured against being pulled off the external position sensor housing.

5.5. Selection of the process valve type (D4 series)

After assembling the device on a process valve of the D4 series, it is necessary to set the DIP switches DIP 3+4 on the electronic modules (see “Fig. 15” at next page) to select the process valve types:

Process valve type	DIP3	DIP4	DIP1	DIP2
D4	0	0	DIP switches for setting the colour combinations, see chapter “13.1” on page 75.	
DA4	1 (ON)	0		
D4SL	0	1 (ON)		
D4PMO	1 (ON)	1 (ON)		

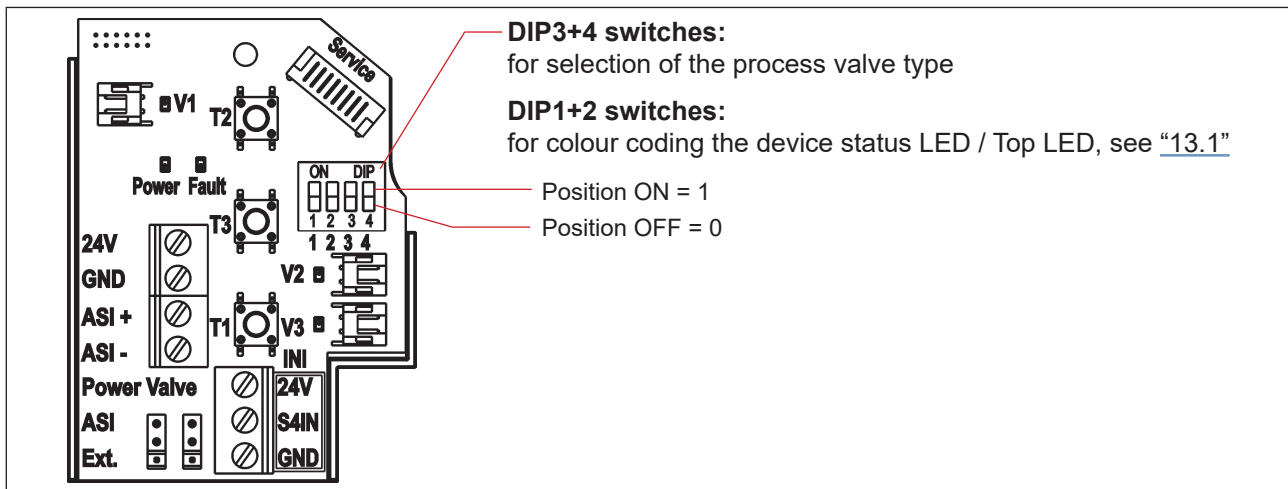

Fig. 15: DIP switches for setting the colour coding and selecting process valve type (example: AS-i electronic module)



5.6. Assembly of the pneumatic and electrical connections

Pneumatic installation:

see chapter "[7. Pneumatic Installation](#)"

Electrical installation:

24 V DC: see chapter "[8. 24 V DC - Design](#)" on page 37,

AS interface: see chapter "[9. AS Interface - Design](#)" on page 43,

DeviceNet: see chapter "[10. DeviceNet - Design](#)" on page 53.

5.7. Recommended auxiliary materials

Silicone grease for easy lubrication of the EPDM seals

6. OPENING AND CLOSING THE HOUSING

6.1. Safety instructions

DANGER!

Risk of injury due to electric shock!

- ▶ Before opening the hood and prior to reaching into the system, switch off the power supply and secure to prevent restarting!
- ▶ Observe applicable accident prevention and safety regulations for electrical equipment!

WARNING!

Risk of injury due to high pressure in the system!

- ▶ Before loosening lines and valves, turn off the pressure and vent the lines.

Risk of injury due to unintentional activation of the system and uncontrolled restart!

- ▶ Secure system against unintentional activation; following assembly, ensure a controlled restart.

CAUTION!

Risk of injury due to improper installation!

- ▶ Installation may be carried out by trained technicians only and with the appropriate tools!

6.2. Opening and closing the housing

6.2.1. Opening the housing of the device

NOTE!

Improper handling will damage the plastic hood / seal!

- Do not use excessive force (e.g. by knocks) for opening.
- Make sure that the lubricated seal contour is not soiled when the hood is placed down as this might reduce the IP protection!

Procedure:

- Remove lead seal if the housing is secured at the sealing lug – see “[Fig. 16](#)”.
- Open the plastic hood by turning counterclockwise (all the way, approx. 1.5 cm).
Due to the tightness of the sealing, loosen the plastic hood by carefully tilting it laterally and lift it upwards to remove it.

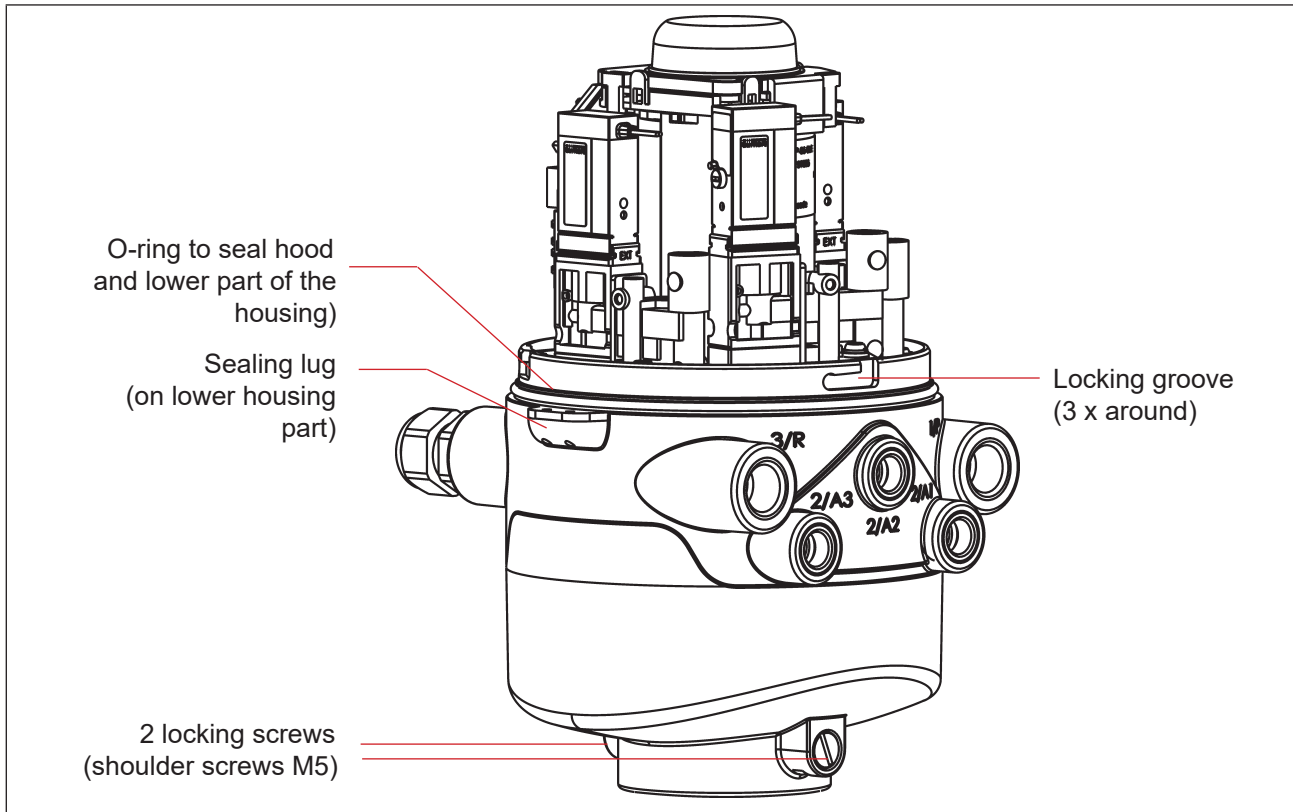

Fig. 16: Sealing and locking the housing

6.2.2. Closing the housing of the device



If necessary, clean the seal contour of the seal and of the hood and lightly lubricate it using a silicone grease.

Caution:

Do not use any petroleum-based or synthetic lubricants (except for silicone grease)!

Procedure:

- Put the plastic hood on the lower part such that the inner "lugs" of the hood are positioned over the locking grooves and the external sealing lugs are positioned almost over each other. Press the hood completely over the O-ring of the lower part – see also "Fig. 16".
- Turn the hood by approx. 1.5 cm clockwise (meaning until the sealing lugs are positioned over each other).
- If necessary, apply a lead seal at the sealing lug to prevent opening without a tool.

7. PNEUMATIC INSTALLATION

7.1. Safety instructions

WARNING!

Risk of injury due to high pressure in the system!

- ▶ Before loosening lines and valves, turn off the pressure and vent the lines.

Risk of injury due to unintentional activation of the system and uncontrolled restart!

- ▶ Secure system against unintentional activation.
- ▶ Following installation, ensure a controlled restart.

CAUTION!

Risk of injury due to improper installation!

- ▶ Installation may be carried out by trained technicians only and with the appropriate tools!

7.2. Pneumatic connection of 8681 Control Unit - D4

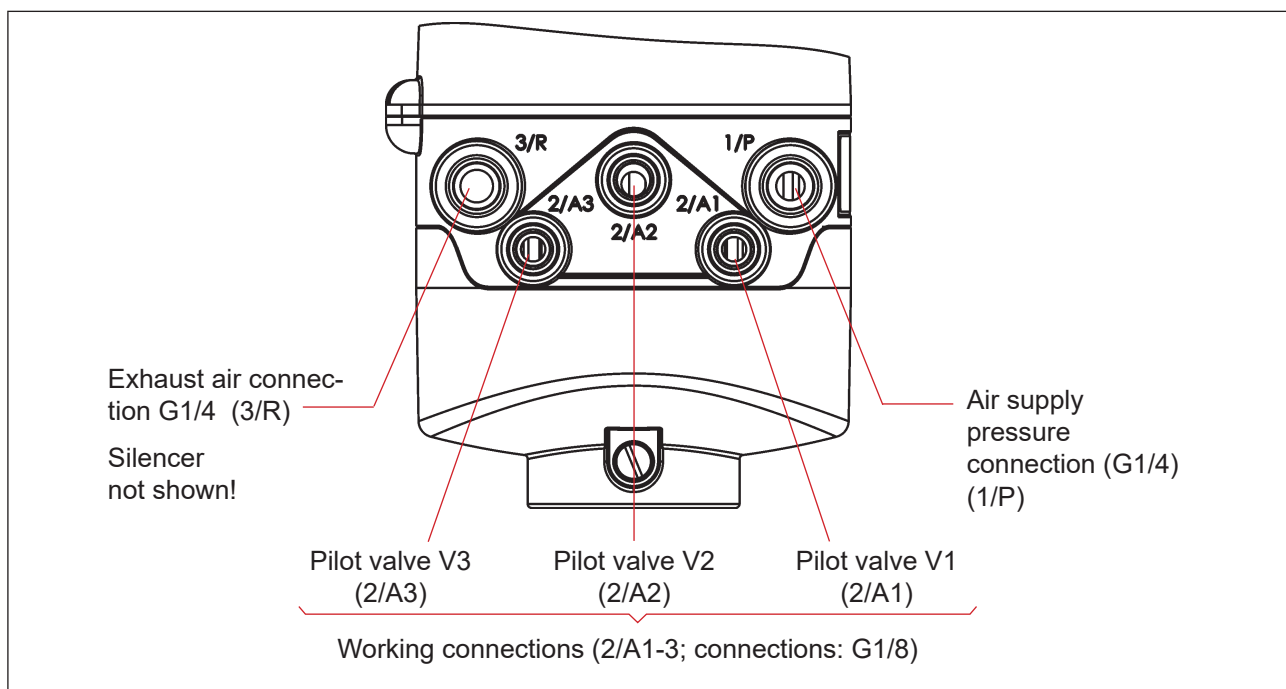

Fig. 17: Pneumatic connections

Procedure:

- If required, realign the device (see chapter "5.4. Realignment of the 8681 Control Unit - D4").
- A silencer has already been mounted on the exhaust air connection (3/R - see "Fig. 17") in the supplied state. As needed, the silencer can be replaced by an exhaust air hose (e.g. after sci

appropriate plug-in hose connectors) – see NOTE-box and recommendation box below.

→ Connect the required working connections **2/A1 to 2/A3** with the corresponding connections on the process valve (according to the number of pilot valves in the device) - compare "Fig. 17".

→ Connect the supply line to air supply pressure connection **1/P** (observe the permissible pressure range, see chapter "4.5. Pneumatic data" on page 20).

NOTE!

Details about permissible hose pipes:

- ▶ Only use approved hose pipes with $\varnothing 6$ mm (or 1/4") or $\varnothing 8$ mm (or 5/16") outer diameters (tolerance: +0.05/-0.1 mm).
- ▶ Only use suitable hose qualities (in particular for high ambient temperatures) that bear up under common stresses caused by the quick connector.
- ▶ Only use a suitable hose cutter when cutting hose pipes. This will safeguard against damage and impermissible deformation.
- ▶ Accordingly dimension hose length to prevent that the hose ends in the plug-in hose connectors generate any diagonally pulling stresses (curved outlet without eccentric stress).

Use of silencer or exhaust air hose?

- ▶ When using an exhaust air hose, accordingly dimension its length to ensure that a Q_{Nn} value >620 l/min is reached.



Recommendation:

Dimension the hose lengths so that the device can be removed from the process valve if required without any additional disassembly work.

7.3. Flow restriction function of the pilot valves



Set the flow restriction screws of the pilot valves only when needed and after completion of all necessary installations!

The flow restriction screws of the pilot valves (see "Fig. 18") are used for individual setting the air intake and exhaust for the working connections and so be able to affect the expansion and retraction rates of the process valve.

- Factory setting of nominal flow rate: Q_{Nn} approx. 110 l/min.
- The flow restriction screws do not serve any sealing function.
- Only tighten the flow restriction screws to the stopper, otherwise damage to device may occur.
- Only use appropriate screwdrivers ($b \leq 3$ mm).



When setting the retraction and extension rates of the pneumatic actuator, ensure that there is no constant "primary pressure" during deaeration!

Keep in mind that the working conditions in the process valve area on the side of the product (flow types, pressure variations) may result in changes in the set aeration and deaeration times.

Settings of the flow-rate or the control speed with the help of the flow restriction screws:



For proper setting, it is advisable to **turn the two flow restriction screws initially into the minimum flow-rate position**. The process valve will then initially move slowly so that you have more time to find the optimum setting during a switching operation.

Minimizing the flow rate: turn clockwise

Maximizing the flow rate: turn counterclockwise

- Open the housing following the instructions in chapter [“6. Opening and Closing the Housing”](#).
- Observing the safety guidelines, activate the respective valve location to be set (either using the system control or the manual controls).
- Turn the flow restriction screw "P" counterclockwise to set the required flow rate and therefore the opening time for the process valve (tool: flat-blade screwdriver, width ≤ 3 mm).
- After that deactivate the respective valve location (V1, V2 or V3).
- Turn the flow restriction screw "R" counterclockwise to set the required flow rate and therefore the closing time for the process valve.

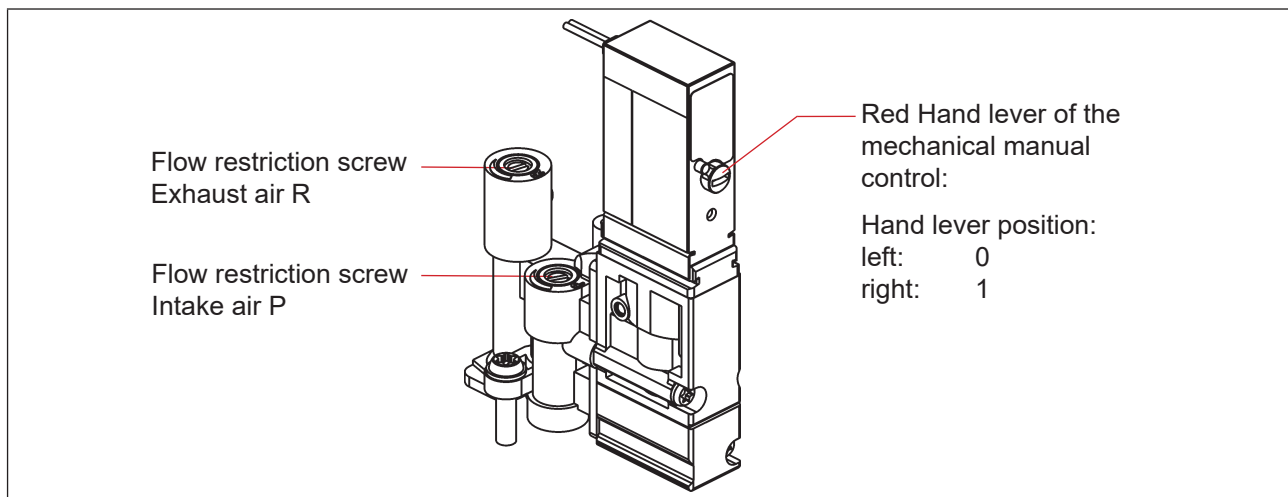

Fig. 18: Flow restriction screws and mechanical manual control of the pilot valves

NOTE!

To avoid unintentional switching of the process valve:

- Makes sure that all manual controls have been deactivated (hand lever all the way left, as pictured) after the setting work has been completed!

- If no further installation work is required, close the housing following the instructions in chapter [“6. Opening and Closing the Housing”](#).



If no system status is available during setting, readjust the system under system operation conditions if necessary.

Observe the safety guidelines during this! See chapter [“2.2. Basic Safety Instructions”](#).

8. 24 V DC - DESIGN

8.1. Electrical connection

	<p>Connection left: for voltage and signals (M12 plug according to IEC 61076-2-101, 12-pole, cable length ca. 80 cm)</p> <p>Connection right: for external position sensor (M12 plug according to IEC 61076-2-101, 4-pole, cable length ca. 20 cm)</p>
---	--

Fig. 19: Connection concept 24 V DC

8.2. Electrical data

Power supply: 12 ... 28 V DC, residual ripple 10%

Connections: **For power supply and signals:** 1 x M16 x 1.5 cable gland / SW22 with multi-pole connection (M12 plug according to IEC 61076-2-101, 12-pole, cable length ca. 80 cm)

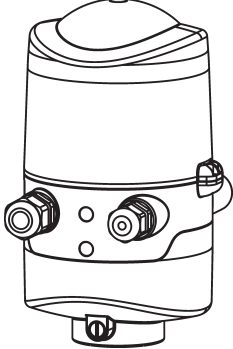
For external position sensor: 1 x M16 x 1.5 cable gland/SW19 with multi-pole connection (M12 plug according to IEC 61076-2-101, 4-pole, cable length ca. 20 cm)

Power consumption (standby current): 30 mA at 24 V DC

Pilot valves:
Typ. switching capacity: 0.9 W (per pilot valve, for 200 ms after switching on)
Typ. continuous output: 0.6 W (per pilot valve, from 200 ms after switching on)
Power consumption per Pilot valve:

50 mA at 12 V DC
25 mA at 24 V DC
22 mA at 28 V DC

Operating mode: Long-term operation (100% ED)

Central display of switching states: ca. 42 mA with a power supply of 24 V DC per illuminated display; colour switching see chapter [“13. LED Colour Assignments”](#)

Outputs/binary feedback signals: S1 out - S4 out
Design: Normally open contact, PNP output
short-circuit-proof, with self-locking short-circuit protection

Switchable output current: max. 100 mA per feedback signal
Output voltage - active: \geq (operating voltage - 2 V)
Output voltage - inactive: max. 1 V in unloaded state

Inputs valve actuation (Y1 - Y3):

Signal level - active:	$U > 10 \text{ V}$, max. 24 V DC + 10%
Signal level - inactive:	$U < 5 \text{ V}$
Impedance:	$> 30 \text{ k}\Omega$

8.3. Design aid

Power consumption of the electronics:	
$P_{EI} = 0.7 \text{ W}$	or $I_{EI} = 30 \text{ mA}$ at 24 V
Power consumption of a valve during activation (200 ms):	
$P_{\text{Valve-ON}} = 0.9 \text{ W}$	or $I_{\text{Valve-ON}} = 38 \text{ mA}$ at 24 V
Power consumption of a valve after reduction:	
$P_{\text{Valve}} = 0.6 \text{ W}$	or $I_{\text{Valve}} = 25 \text{ mA}$ at 24 V
Power consumption of an optical position report:	
$P_{\text{LED}} = 1.0 \text{ W}$	or $I_{\text{LED}} = 42 \text{ mA}$ at 24 V



Also, if several pilot valves of the device were to be opened simultaneously, the switch signal will be sent staggered to the valves. Only *one* 0.9 W valve will ever be recorded.

Calculation examples:

Example 1:								
3 valves are activated simultaneously, one position is reported (state for 200 ms):								
P_{Total}	$=$	P_{EI}	$+$	$1 \times P_{\text{Valve-ON}}$	$+$	$2 \times P_{\text{Valve}}$	$+$	$1 \times P_{\text{LED}}$
$=$								
3.8 W	=	0.7 W	+	1 x 0.9 W	+	2 x 0.6 W	+	1 x 1.0 W
or								
I_{Total}	$=$	I_{EI}	$+$	$1 \times I_{\text{Valve-ON}}$	$+$	$2 \times I_{\text{Valve}}$	$+$	$1 \times I_{\text{LED}}$
$=$								
160 mA	=	30 mA	+	1 x 38 mA	+	2 x 25 mA	+	1 x 42 mA

Example 2:						
3 valves have been activated simultaneously, one position is reported (persistent state):						
P_{Total}	$=$	P_{EI}	$+$	$3 \times P_{\text{Valve}}$	$+$	$1 \times P_{\text{LED}}$
$=$						
3.5 W	=	0.7 W	+	3 x 0.6 W	+	1 x 1.0 W
or						
I_{Total}	$=$	I_{EI}	$+$	$3 \times I_{\text{Valve}}$	$+$	$1 \times I_{\text{LED}}$
$=$						
147 mA	=	30 mA	+	3 x 25 mA	+	1 x 42 mA

8.4. Safety instructions

DANGER!

Risk of injury due to electric shock!

- ▶ Before reaching into the system, switch off the power supply and secure it to prevent restarting!
- ▶ Observe applicable accident prevention and safety regulations for electrical equipment!
- ▶ When setting the position measuring system (Teach), do not contact any live components!

WARNING!

Risk of injury due to unintentional activation of the system and uncontrolled restart!

- ▶ Secure system against unintentional activation; following assembly, ensure a controlled restart.

CAUTION!

Risk of injury due to improper installation!

- ▶ Installation may be carried out by trained technicians only and with the appropriate tools!

8.5. Electrical installation / start-up

Internal cabling work is not required for devices with multi-pole connection, which makes installation and start-up on site considerably easier and quicker, reducing the risk of leaks.

→ Connect the 80 cm cable with M12 (12 pole) to the PLC

24 V DC Electronics module, terminal strip configuration:

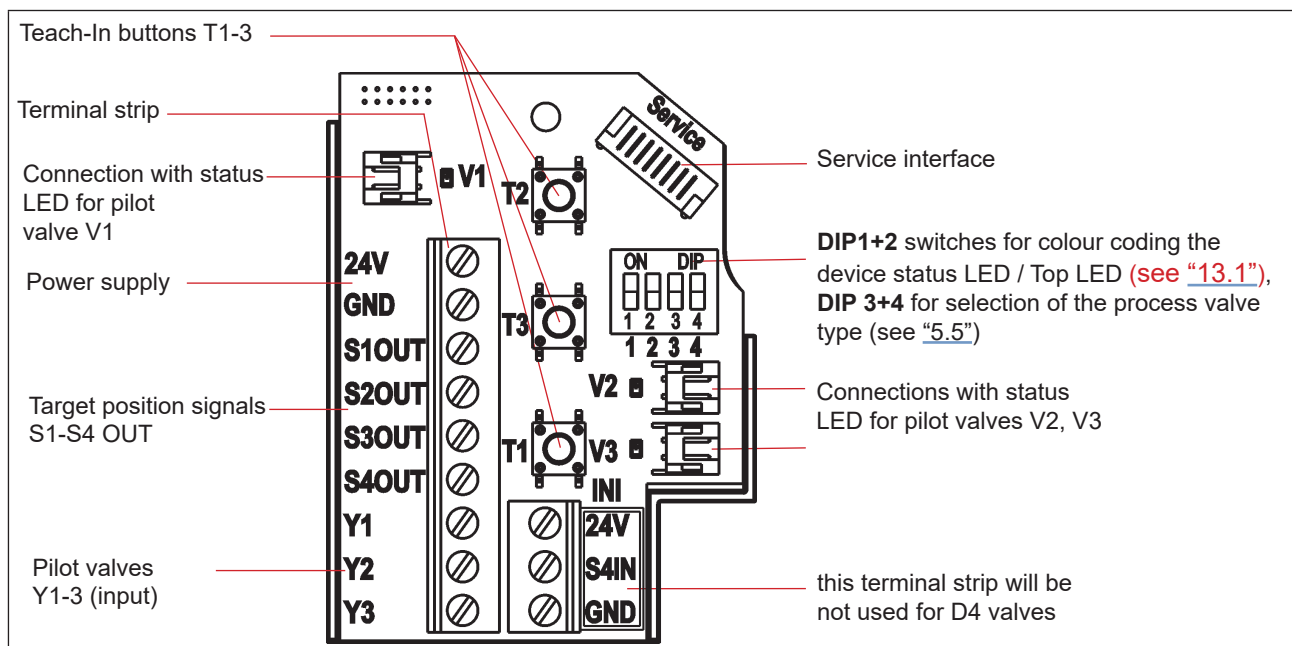

Fig. 20: 24 V DC electronic module

Input and output signals to the higher-level control (PLC):

Pin	Designation on electr. module	Configuration	Connector M12, 12-pole
1	24 V	Power supply 24 V	<p>View onto the plug pins:</p>  <p>The center pins (10, 11, 12) are not used</p>
2	GND	GND	
3	S1 out	Process valve state (depending on the valve type - see tables below in "8.6")	
4	S2 out		
5	S3 out		
6	S4 out		
7	Y1	Pilot valve V1 input	
8	Y2	Pilot valve V2 input	
9	Y3	Pilot valve V3 input	
10		Not used	
11		Not used	
12		Not used	

Table 1: Connection configuration, circular plug-in connector M12 x 1.0, male (acc. to IEC 61076-2-101)

8.6. Logic tables for the valve D4 series

The following logic tables work internally in the device, the combination of the single (target) signals S1-S4 results in the final signal for the valve state (indicated with the device status LED/Top LED).

The combination of the target signals S1-S4 for a special valve state depends on the valve type - see the following tables:

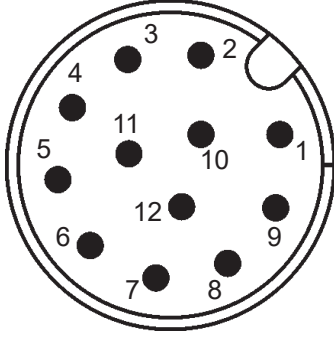
8.6.1. Logic tables for SPX D4:

Output data Control Unit	valve state	linear sensor 2 (teach data) (external position sensor)		linear sensor 1 (teach data) (internal position sensor)	
		S1	S2	S3	S4
S1 out	closed	1	0	1	0
S2 out	open	0	0	0	1

Input data Control Unit	Pilot V1 (main stroke)
Y1	1
Y2	0
Y3	0

8.6.2. Logic tables for SPX DA4

Output data Control Unit	valve state	linear sensor 2 (teach data) (external position sensor)		linear sensor 1 (teach data) (internal position sensor)	
		S1	S2	S3	S4
S1 out	closed	1	0	0	0
S2 out	open	0	0	0	1
S3 out	upper seat lift	0	1	0	0
S4 out	lower seat lift	1	0	1	0

Input data Control Unit	Pilot V1 (main stroke)	Pilot V2 (upper seat lift)	Pilot V3 (lower seat lift)
Y1	1	0	0
Y2	0	1	0
Y3	0	0	1

8.6.3. Logic tables for SPX D4SL

Output data Control Unit	valve state	linear sensor 2 (teach data) (external position sensor)		linear sensor 1 (teach data) (internal position sensor)	
		S1	S2	S3	S4
S1 out	closed	1	0	1	0
S2 out	open	0	0	0	1
S3 out	upper seat lift	0	1	1	0
S4 out	lower seat lift	1	0	0	0

Input data Control Unit	Pilot V1 (main stroke)	Pilot V2 (upper seat lift)	Pilot V3 (lower seat lift)
Y1	1	0	0
Y2	0	1	0
Y3	0	0	1

8.6.4. Logic tables for SPX D4PMO

The Control Unit output data of this valve type are the sensor signals of the taught positions, not the valve state – see the following tables.

The valve state combination table has to be implemented in the PLC software.

The opposite valve shaft remains in “closed position” during seat lift - this can be monitored by observing the appropriate sensor position signal.



Logic tables for SPX D4PMO:

valve state	linear sensor 2 (teach data) (external position sensor)		linear sensor 1 (teach data) (internal position sensor)	
	S1	S2	S3	S4
closed	1	0	1	0
open	0	0	0	1
upper seat lift	0	1	1	0
lower seat lift	1	0	0	0
Output data Control Unit	S1 out	S2 out	S3 out	S4 out

Input data Control Unit	Pilot V1 (main stroke)	Pilot V2 (upper seat lift)	Pilot V3 (lower seat lift)
Y1	1	0	0
Y2	0	1	0
Y3	0	0	1

9. AS INTERFACE - DESIGN

9.1. Definition

AS interface connection:

AS interface (Actuator Sensor Interface) is a field bus system which is used primarily for networking binary sensors and actuators (slaves) with a higher-level control (master).



Connecting the Control Units - D4 to higher bus systems is possible using commercially available gateways. Contact your distribution partner in this regard.

Bus line:

Unshielded two-wire line (AS interface line as AS interface cable harness) along which both information (data) and energy (power supply for the actuators and sensors) are transmitted.

Network topology:

Freely selectable within wide limits, i.e. star, tree and line networks are possible. Further details are described in the AS interface specification (A/B slave model complies with the version 3.0 specification).

The Control Units - D4 have been configured as AS interface version with an extended address range (A/B slaves) for 62 slaves or optionally as an AS interface version for 31 slaves. For details, see chapter [“9.9. Programming data”](#).

9.2. Electrical connection for AS interface

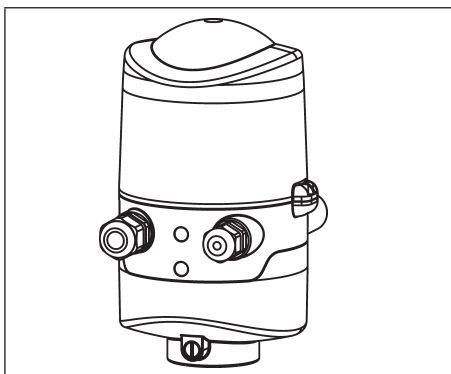

Connection left:	for voltage and signals (M12 plug according to IEC 61076-2-101, 4-pole, cable length ca. 80 cm)
Connection right:	for external position sensor (M12 plug according to IEC 61076-2-101, 4-pole, cable length ca. 20 cm)

Fig. 21: AS interface connection concept

9.3. Number of connectable Control Units - D4

The level of expansion that is actually possible depends on the total number of all individual operating currents for each device, which are supplied via the bus at the common AS interface bus segment (see example calculation in chapter "[9.6. Design aid](#)").

Standard: AS interface/62 slaves:

(AS interface version with extended addressing range (A/B slave))

In AS interface versions with extended addressing range (A/B slave), 1 master can communicate with 62 slaves.

Option: AS interface/31 slaves:

(AS interface version with 31 slave addressing range)

In this case, a maximum of 31 Control Units - D4 can be connected to a bus line (address range restriction).

9.4. Maximum length of the bus line

The bus cable may be a **maximum of 100 m long**. All AS interface lines of an AS interface string must be considered for the design, i.e. even the drop lines to the individual slaves.

The M12 plug multipole connection with a cable of ca. 80 cm long has to be **calculated with 1 m length** because of the internal cabling in the device.

Example for determining the cable length:

For a multi-pole connection with ca. 80 cm cable:

When using 62 Control Units - D4, the AS interface cable harness may still be $(100 \text{ m} - 62 * 1 \text{ m}) = 38 \text{ m}$ long.

If the calculated line length of 100 m were to be exceeded, a commercially available AS interface repeater may be used, as needed.



Observe maximum power supply via certified AS interface power supply units $\leq 8 \text{ A}$!
For details see AS interface specification.

Observe the optional design "**AS Interface with External Power Supply**" to reduce the load on the AS interface bus segment! (see chapters "[9.5](#)" and "[9.8](#)")



Use cables according to the AS interface specification.
If other cables are used, the maximum cable length will change.

9.5. Electrical data

Comments / notes:

The device was developed according to the Complete Specification (V.3.0) and the Profile S-7.A.E and S-7.F.F of the AS International Association.

Outputs (from master perspective):	1 or 3 pilot valves
Inputs (from master perspective):	4 binary feedback signals (process valve states: closed, open, upper seat lift, lower seat lift)
Watchdog:	If bus communication fails for more than 50 to 100 ms, the outputs are set to 0

Setting the **pilot valves' power supply** using jumpers on the AS interface electronic module - see "[Fig. 25: AS-i electronic module](#)":

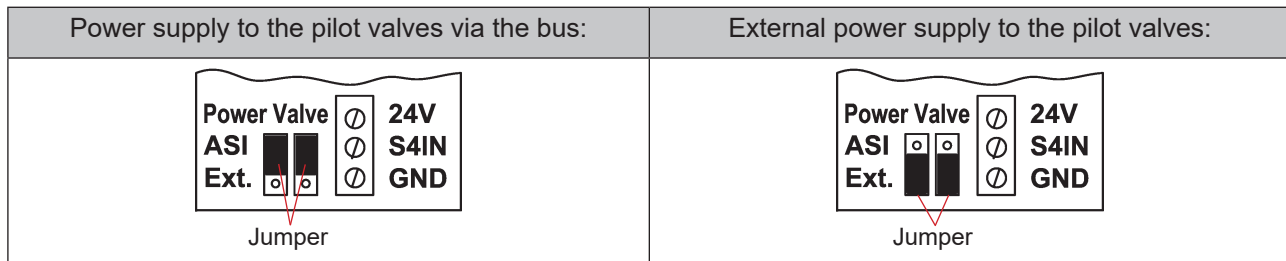

Fig. 22: Jumper setting on AS-i electronic module: Power supply to the pilot valves via the bus or externally

Connections:

Multi-pole connection: **For power supply and signals:** 1 x M16 x 1.5 cable gland / SW22 with multi-pole connection (M12 plug according to IEC 61076-2-101, 4-pole, cable length ca. 80 cm)

For external position sensor: 1 x M16 x 1.5 cable gland/SW19 with multi-pole connection (M12 plug according to IEC 61076-2-101, 4-pole, cable length ca. 20 cm)

Power supply: 29.5 ... 31.6 V DC (according to specification)
21.0 ... 31.6 V DC (according to specification Power24)

Inputs (from master perspective) / binary feedback signals:

The recovery of the 4 valve positions reported back in binary format is described in chap. "[11](#)" on page 70.

Outputs (from master perspective) / pilot valves:

Typ. switching capacity: 0.9 W (per pilot valve, for 200 ms after switching on)
Typ. continuous output: 0.6 W (per pilot valve, from 200 ms after switching on)

Watchdog function: integrated

Output reduction: via AS interface - electronics integrated
Typ. Pull-in current (per sol. valve): 30 mA or 0.9 W/200 ms (at 30.5 V AS-i voltage)
Typ. Holding current (per sol. valve): 20 mA or 0.6 W (at 30.5 V AS-i voltage)
Operating mode: Long-term operation (100% ED)
Valve type: Type 6524

Central display of the switching states:

Power consumption from AS interface
at 30.5 V AS interface voltage: ca. 33 mA or 1 W per illuminated display

Number of representable colours: 2 colours for process valve switching states
1 colour for signaling a fault
For "universal colour switching" see chapter ["13. LED Colour Assignments"](#).

Power supply via AS interface bus (without external power supply):

Max. power consumption from AS-i: <160 mA
Power consumption during normal operation from the
AS-i (after current reduction): <150 mA
3 valves activated, 1 position reported back by LED display

Integrated short-circuit protection

NOTE!

If all 3 pilot valves are simultaneously controlled via the AS interface, the electronics will activate the valves sequentially with a 200 ms time delay to protect the bus from overloads.



Please observe the notes on power requirement and maximum expansion stage of the AS interface network contained in chapter ["9.3. Number of connectable Control Units - D4"D4s"](#) and in the AS-i specifications, where applicable.

External power supply for pilot valves:

External power supply: 19.2 V DC to 31.6 V DC
The power supply unit must include a secure disconnect in accordance with IEC 60364-4-41. It must conform to the SELV standard. The ground potential must not have a ground connection.

Power consumption from external power supply for outputs (pilot valves) - without integrated current limiting: <110 mA at 24 V DC (for 200 ms after switching on of the 3.rd valve)

Power consumption from AS-i
for inputs and display: <150 mA (incl. feedback and fault display)

Integrated short-circuit protection



Please observe the notes on power requirement and maximum expansion stage of the AS interface network contained in chapter ["9.3. Number of connectable Control Units - D4"D4s"](#) and in the AS-i specifications, where applicable.

9.6. Design aid

Design aid for power supply of the valves via the AS-i bus

Power consumption of the electronics:				
P_{EI}	=	1.0 W	or	I_{EI} = 33 mA at 30.5 V
Power consumption of a valve during activation (200 ms):				
$P_{Valve-ON}$	=	0.9 W	or	$I_{Valve-ON}$ = 30 mA at 30.5 V
Power consumption of a valve after reduction:				
P_{Valve}	=	0.6 W	or	I_{Valve} = 20 mA at 30.5 V
Power consumption of an optical position report:				
P_{LED}	=	1.0 W	or	I_{LED} = 33 mA at 30.5 V

For the design of the **maximum line lengths**, observe chapter [“9.3. Number of connectable Control Units - D4”D4s”](#).



Even if several pilot valves of the device are switched simultaneously via the bus, the switching signal is passed on to the valves in staggered order, i.e. only *one* valve is ever taken up 0.9 W.

Calculation examples:

Example 1:				
3 valves are activated “simultaneously”, one position is reported (state for 200 ms):				
P_{Slave}	=	P_{EI}	+ 1 x $P_{Valve-ON}$	+ 2 x P_{Valve} + 1 x P_{LED}
4.1 W	=	1.0 W	+ 1 x 0.9 W	+ 2 x 0.6 W + 1 x 1.0 W
or				
I_{Slave}	=	I_{EI}	+ 1 x $I_{Valve-ON}$	+ 2 x I_{Valve} + 1 x I_{LED}
136 mA	=	33 mA	+ 1 x 30 mA	+ 2 x 20 mA + 1 x 33 mA

Example 2:				
3 valves have been activated “simultaneously”, one position is reported (persistent state):				
P_{Slave}	=	P_{EI}	+ 3 x P_{Valve}	+ 1 x P_{LED}
3.8 W	=	1.0 W	+ 3 x 0.6 W	+ 1 x 1.0 W
or				
I_{Slave}	=	I_{EI}	+ 3 x I_{Valve}	+ 1 x I_{LED}
126 mA	=	33 mA	+ 3 x 20 mA	+ 1 x 33 mA

9.7. Safety instructions

DANGER!

Risk of injury due to electric shock!

- ▶ Before reaching into the system, switch off the power supply and secure it to prevent restarting!
- ▶ Observe applicable accident prevention and safety regulations for electrical equipment!
- ▶ When setting the position measuring system (Teach), do not contact any live components!

WARNING!

Risk of injury due to unintentional activation of the system and uncontrolled restart!

- ▶ Secure system against unintentional activation; following assembly, ensure a controlled restart.

CAUTION!

Risk of injury due to improper installation!

- ▶ Installation may be carried out by trained technicians only and with the appropriate tools!

9.8. Electrical installation of the AS interface

Internal cabling work is not required for any of the AS Interface designs with multi-pole connection, which makes installation and start-up on site considerably easier and quicker, reducing the risk of leaks.

However, you will require the correspondingly assembled cable sets with the following pin assignments (see “Fig. 23” and table below).

Likewise, the jumpers on the electronic module must be set correspondingly (see “Fig. 22” and “Fig. 25”).

Bus connection for AS interface and power supply:

AS-i bus and power supply for pilot valves via bus or external power supply (see also “Fig. 22”):

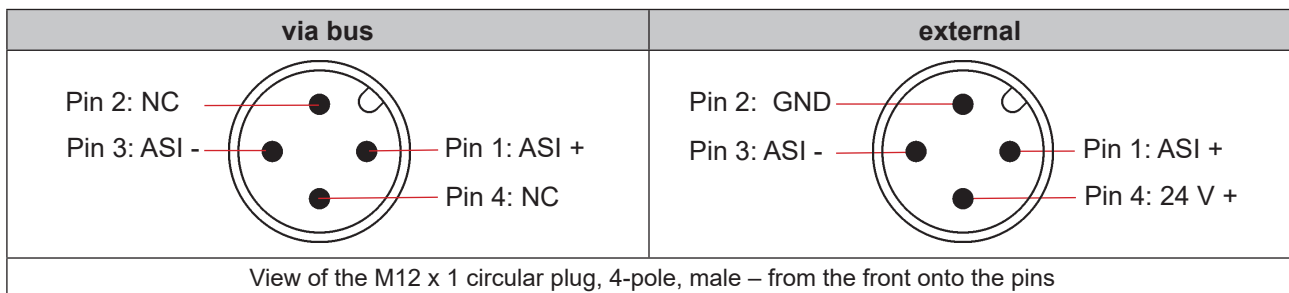

Fig. 23: AS interface bus connection (power supply for pilot valves via bus or external power supply)

Pin	Configuration (supply via bus)	Configuration (external power supply)	Wire colour
1	AS interface - ASI+	AS interface - ASI +	brown
2	Not used	GND	white
3	AS interface - ASI –	AS interface - ASI –	blue
4	Not used	24 V +	black

The cable with multi-pole connection version is especially suited for direct and flexible connection to the AS interface cable harness using the ribbon cable terminal (M12 branch circuit, VA branch circuit) that is optionally available.

The optional ribbon cable terminal contacts the AS interface cable harness by means of penetration technology which allows installation by "clipping in" the AS interface cable harness without cutting and without removing insulation.

 <p>Screw, 2x</p> <p>Branch circuit M12 plug-in connector</p>	<p>Procedure:</p> <ul style="list-style-type: none"> → Open the ribbon cable terminal (loosen screws and remove cover) → Insert cable harness → Close ribbon cable terminal again → Tighten the screws Loosen the thread-forming screws slightly and position them on the existing threaded hole and screw in.
--	---

Fig. 24: Optional ribbon cable terminal for AS interface cable harness

AS interface electronic module - LED status displays:

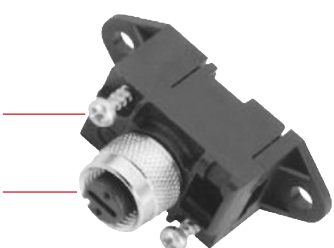
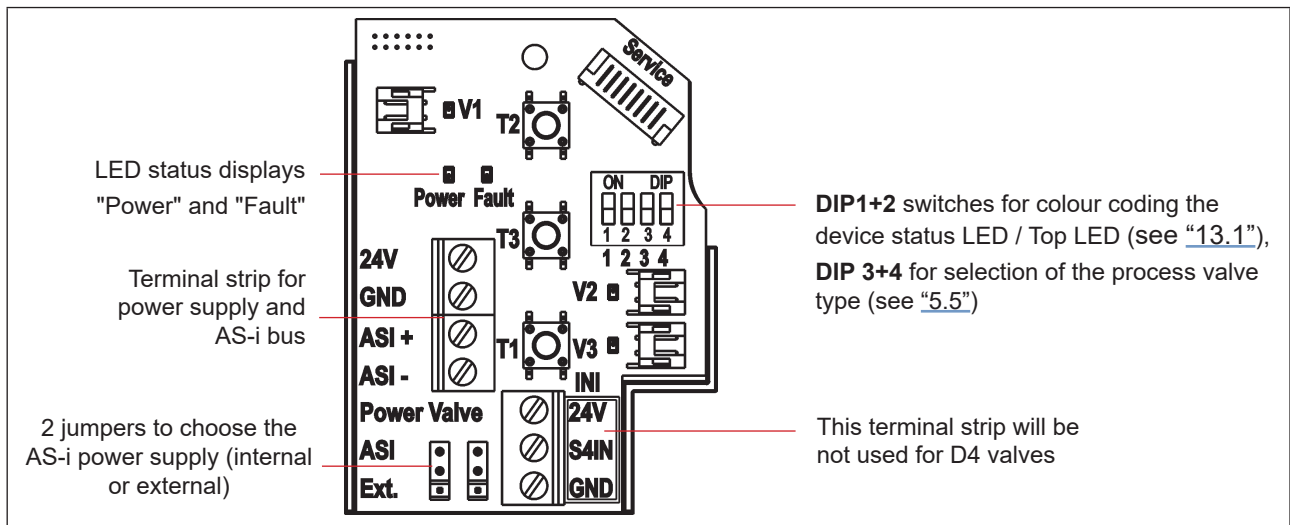

Fig. 25: AS-i electronic module

LED 1 "Power" (green)	LED 2 "Fault" (red)	signalized status
off	off	Power OFF
on	off	OK
on	on	No data traffic (expired Watchdog at slave address does not equal 0)
flashing	on	Slave address = 0
flashing	flashing	Sensor supply overload / manual actuation activated / untaught / service/ maintenance request / PC service program service mode

! The central multi-colour status display (device status LED / Top LED) flashes also in the fault colour (see chapter "13.2. Blinking pattern & fault signaling"), if the status LED 2 "Fault" on the electronic module is active.

9.9. Programming data

The Control Units - D4 have been configured as AS interface version with an extended address range (A/B slaves) for 62 slaves or optionally as an AS interface version for 31 slaves.



A change between both device configurations (for 62 slaves or 31 slaves) is only possible by exchanging the electronic module (PCB).

If one device is replaced with another device having a different configuration in the AS interface field bus system (e.g. AS interface version 62 slaves (A/B-Slave) to replace a device with AS interface version 31 slaves), a configuration error will be generated at the master due to the different ID codes!

In this case (intentional replacement!), the current configuration must be re-programmed in the AS interface master. Please read the operating instructions of the used AS interface master!

AS-i address factory setting:

AS-i address = 0



The change or subsequent activation of a value (usually) requires a device restart.

9.9.1. Programming data table

	Programming data for 62 slaves AS interface - Device for A/B slave addressing (default device)	Programming data for 31 slaves AS interface (optional)
I/O configuration	7 hex (4 inputs / 4 outputs) see below: Bit configuration table	7 hex (4 inputs / 4 outputs) see below: Bit configuration table
ID code	A hex	F hex
Extended ID code 1	7 hex	(F hex)
Extended ID code 2	E hex	(F hex)
Profile	S-7. A.E	S-7. F.F

9.9.2. Logic tables for the valve D4 series

The following logic tables work internally in the device, the combination of the single (target) signals S1-S4 results in the final signal for the valve state (indicated with the device status LED/Top LED).

The combination of the target signals S1-S4 for a special valve state depends on the valve type (see tables below):



Logic tables for SPX D4:

AS-i data INPUT data	valve state	linear sensor 2 (teach data) (external position sensor)		linear sensor 1 (teach data) (internal position sensor)	
		S1	S2	S3	S4
DI0	closed	1	0	1	0
DI1	open	0	0	0	1

AS-i data OUTPUT data	Pilot V1 (main stroke)
DO0	1
DO1	0
DO2	0
DO3	not used

Logic tables for SPX DA4:

AS-i data INPUT data	valve state	linear sensor 2 (teach data) (external position sensor)		linear sensor 1 (teach data) (internal position sensor)	
		S1	S2	S3	S4
DI0	closed	1	0	0	0
DI1	open	0	0	0	1
DI2	upper seat lift	0	1	0	0
DI3	lower seat lift	1	0	1	0

AS-i data OUTPUT data	Pilot V1 (main stroke)	Pilot V2 (upper seat lift)	Pilot V3 (lower seat lift)
DO0	1	0	0
DO1	0	1	0
DO2	0	0	1
DO3	not used		

Logic tables for SPX D4SL:

AS-i data INPUT data	valve state	linear sensor 2 (teach data) (external position sensor)		linear sensor 1 (teach data) (internal position sensor)	
		S1	S2	S3	S4
DI0	closed	1	0	1	0
DI1	open	0	0	0	1
DI2	upper seat lift	0	1	1	0
DI3	lower seat lift	1	0	0	0

AS-i data OUTPUT data	Pilot V1 (main stroke)	Pilot V2 (upper seat lift)	Pilot V3 (lower seat lift)
DO0	1	0	0
DO1	0	1	0
DO2	0	0	1
DO3	not used		



Logic tables for SPX D4PMO:

The AS-i INPUT data supplied by the Control Unit for this valve type are the sensor signals of the taught positions, not the valve state – see the following tables.

The valve state combination table has to be implemented in the PLC software.

The opposite valve shaft remains in “closed position” during seat lift - this can be monitored by observing the appropriate sensor position signal.

valve state	linear sensor 2 (teach data) (external position sensor)		linear sensor 1 (teach data) (internal position sensor)	
	S1	S2	S3	S4
closed	1	0	1	0
open	0	0	0	1
upper seat lift	0	1	1	0
lower seat lift	1	0	0	0
AS-i data INPUT data	DI0	DI1	DI2	DI3

AS-i data OUTPUT data	Pilot V1 (main stroke)	Pilot V2 (upper seat lift)	Pilot V3 (lower seat lift)
DO0	1	0	0
DO1	0	1	0
DO2	0	0	1
DO3	not used		



10. DEVICENET - DESIGN

10.1. Definition

- The DeviceNet is a field bus system which is based on the CAN protocol (Controller Area Network). It enables actuators and sensors (slaves) to be networked with higher-level controllers (master).
- The device in the DeviceNet is a slave device according to the Predefined Master/Slave Connection Set stipulated in the DeviceNet specification. Polled I/O, Bit Strobed I/O and Change of State (COS) are supported as I/O connection variants.
- With DeviceNet it is necessary to differentiate between cyclical or event-driven high-priority process messages (I/O Messages) and acyclical low-priority management messages (Explicit Messages).
- The protocol process conforms to the **DeviceNet specification Release April 2010**.

10.2. DeviceNet specification

EDS file:	SPX_CU8681_D4-X.Y.eds (with X.Y = EDS revision)
Icons:	SPX_CU8681_D4-X.Y.ico
Baud rate:	125 kBit/s, 250 kBit/s, 500 kBit/s (can be adjusted using DIP switches 7, 8); factory setting: 125 kBit/s (see chapter “10.10.2. Setting the baud rate”)
Address:	0 ... 63 (via DIP switches 1 ... 6 adjustable); factory setting: 63 (see chapter “10.10.1. Setting of the DeviceNet address”)
Process data:	1 static input assembly (Input: from 8681 Control Unit - D4 to DeviceNet master/scanner) 1 static output assembly (Output: from DeviceNet master/scanner to 8681 Control Unit - D4)
Inputs:	Process valve state <i>or</i> sensor state – dependent on selected process valve type (refer to chapter “5.5” on page 30): D4, DA4, D4SL: <i>valve state</i> (closed, open, upper seat lift, lower seat lift), D4PMO: <i>sensor state</i> (S1, S2, S3, S4); Supply via DeviceNet string (11 ... 25 V DC) Switch level high signal ≥ 5 V Switch level low signal ≤ 1.5 V
Outputs:	3 pilot valves
Power consumption from the bus:	max. output 5 W, if all pilot valves are switched (3 x type 6524 with 0.6 W each)

10.2.1. Total line length and maximum line length according to DeviceNet specification

The bus line is a 4-core cable with additional shielding which must conform to the DeviceNet specification. The cable transmits both information (data) and energy (power supply for low-power actuators and sensors).



The maximum total line length (sum of trunk lines and drop lines) of a network depends on the baud rate.

When designing the network, the calculated cable length at the device must be 1 m - this takes into account the cable lengths installed outside (ca. 80 cm) and inside (ca. 20 cm) the control unit.

Baud rate	Maximum total line length* ¹		
	Thick Cable**	Mid Cable**	Thin Cable**
125 kBit/s	500 m	300 m	100 m for all baud rates
250 kBit/s	250 m	250 m	
500 kBit/s	100 m	100 m	

* According to DeviceNet specification. If a different cable type is used, lower maximum values apply.

** For cable designation and details - see DeviceNet specification.

10.2.2. Drop line length

Baud rate	Length of the drop lines	
	Maximum length	Maximum total length of all drop lines in the network
125 kBit/s	6 m for all baud rates	156 m
250 kBit/s		78 m
500 kBit/s		39 m

10.3. Electrical connection

	<p>Connection left: for voltage and signals</p> <p>(M12 plug according to IEC 61076-2-101, 5-pole, cable length ca. 80 cm)</p>
	<p>Connection right: for external position sensor</p> <p>(M12 plug according to IEC 61076-2-101, 4-pole, cable length ca. 20 cm)</p>

Fig. 26: Connection concept DeviceNet



10.4. Electrical data

Connections:

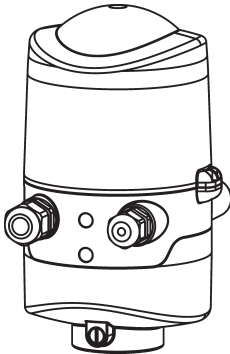
Multi-pole connection: **For power supply and signals:** 1 x M16 x 1.5 cable gland / SW22 with multi-pole connection (M12 plug according to IEC 61076-2-101, 5-pole, cable length ca. 80 cm)

For external position sensor: 1 x M16 x 1.5 cable gland/SW19 with multi-pole connection (M12 plug according to IEC 61076-2-101, 4-pole, cable length ca. 20 cm)

Power supply: 11 ... 25 V DC (according to specification)

Max. power consumption: <200 mA at 24 V DC (200 ms after switching on of the valves)

Inputs (from master perspective) / binary or analog feedback signals:

The recovery of the 3 valve positions reported back in binary format or the analog position signal is described in chapter [“11” on page 70](#).

Outputs (from master perspective) / pilot valves:

Typ. switching capacity:	0.9 W (per pilot valve, for 200 ms after switching on)
Typ. continuous output:	0.6 W (per pilot valve, from 200 ms after switching on)
Power consumption per Pilot valve:	50 mA at 12 V DC 25 mA at 24 V DC 22 mA at 28 V DC
Operating mode:	Long-term operation (100% ED)
Valve types:	6524

Central display of the switching states:

Power consumption from DeviceNet at 24 V DC: ca. 42 mA with a power supply of 24 V DC per illuminated display; colour switching see chapter [“13. LED Colour Assignments” on page 75](#)

10.5. Safety position if the bus fails

If the bus fails, the pilot valve is switched to a programmable safety position (default: pilot valve not energized). For configuration data see chapter [“10.12.1. Configuration of the safety position of pilot valves during a bus error”](#).



10.6. Design aid

Power consumption of the electronics:								
P_{EI}	=	1.44 W	or	I_{EI}	=	60 mA	at	24 V
Power consumption of a valve during activation (200 ms):								
$P_{Valve-ON}$	=	0.9 W	or	$I_{Valve-ON}$	=	38 mA	at	24 V
Power consumption of a valve after reduction:								
P_{Valve}	=	0.6 W	or	I_{Valve}	=	25 mA	at	24 V
Power consumption of an optical position report:								
P_{LED}	=	1.0 W	or	I_{LED}	=	42 mA	at	24 V

Calculation examples:

Example 1:				
3 valves are activated simultaneously, one position is reported (state for 200 ms):				
P_{Total}	=	P_{EI}	+ 3 x $P_{Valve-ON}$	+ 1 x P_{LED}
5.14 W	=	1.44 W	+ 3 x 0.9 W	+ 1 x 1.0 W
or				
I_{Total}	=	I_{EI}	+ 3 x $I_{Valve-ON}$	+ 1 x I_{LED}
216 mA	=	60 mA	+ 3 x 38 mA	+ 1 x 42 mA

Example 2:				
3 valves have been activated simultaneously, one position is reported (persistent state):				
P_{Total}	=	P_{EI}	+ 3 x P_{Valve}	+ 1 x P_{LED}
4.24 W	=	1.44 W	+ 3 x 0.6 W	+ 1 x 1.0 W
or				
I_{Total}	=	I_{EI}	+ 3 x I_{Valve}	+ 1 x I_{LED}
177 mA	=	60 mA	+ 3 x 25 mA	+ 1 x 42 mA

10.7. Safety instructions

DANGER!

Risk of injury due to electric shock!

- ▶ Before reaching into the system, switch off the power supply and secure it to prevent restarting!
- ▶ Observe applicable accident prevention and safety regulations for electrical equipment!
- ▶ When setting the position measuring system (Teach), do not contact any live components!

WARNING!

Risk of injury due to unintentional activation of the system and uncontrolled restart!

- ▶ Secure system against unintentional activation; following assembly, ensure a controlled restart.

CAUTION!

Risk of injury due to improper installation!

- ▶ Installation may be carried out by trained technicians only and with the appropriate tools!

10.8. Electrical installation - DeviceNet

Internal cabling work is not required for any of the DeviceNet designs (cable with multi-pole connection), which makes installation and start-up on site considerably easier and quicker, reducing the risk of leaks.

However, you will require the correspondingly assembled cable sets with the following pin assignments (see "Fig. 27" and table below).

Bus connection for DeviceNet and power supply:

Circular plug M12 x 1, 5-pole, male, cable length ca. 80 cm, the configuration conforms to the DeviceNet specification.

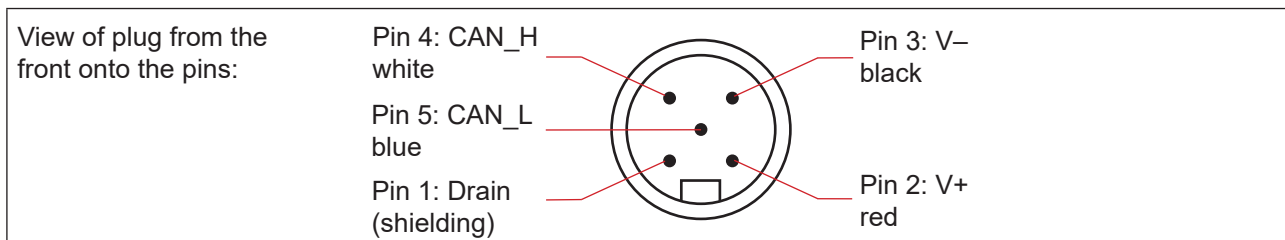

Fig. 27: Bus connection of DeviceNet with power supply

Pin	1	2	3	4	5
Signal	Shielding	V +	V –	CAN_H	CAN_L
Colour		red	black	white	blue

DeviceNet electronic module:

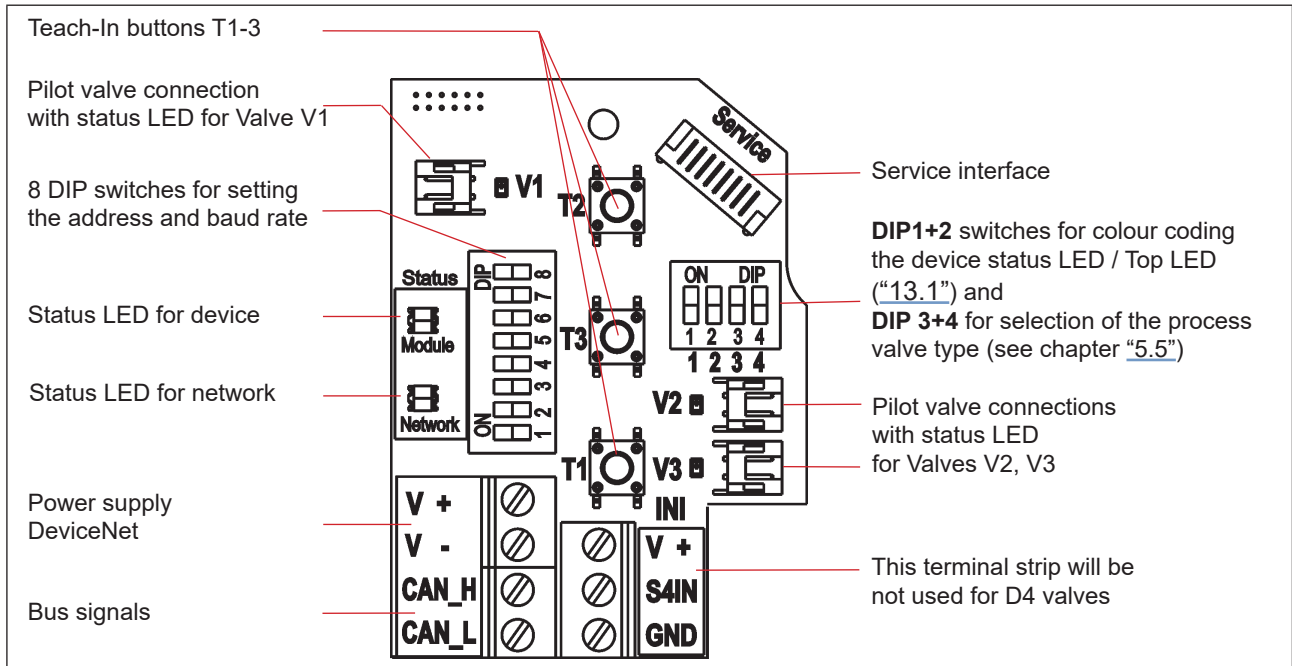

Fig. 28: DeviceNet electronic module

Terminal strip configuration:

Designation Terminal strip	Configuration
V+	Power supply DeviceNet
V -	Power supply DeviceNet
CAN_H	Bus signal CAN high
CAN_L	Bus signal CAN low

10.9. Network topology of a DeviceNet system

When installing a DeviceNet system, ensure that the terminating circuit of the data lines is correct. The circuit prevents the occurrence of interference caused by signals reflected onto the data lines.

The trunk line must be terminated at both ends with resistors of $120\ \Omega$ and $1/4\ W$ power loss (see “Fig. 29: Network topology”).

“Fig. 29” illustrates a line with one trunk line and several drop lines. Trunk lines and drop lines consist of identical material.

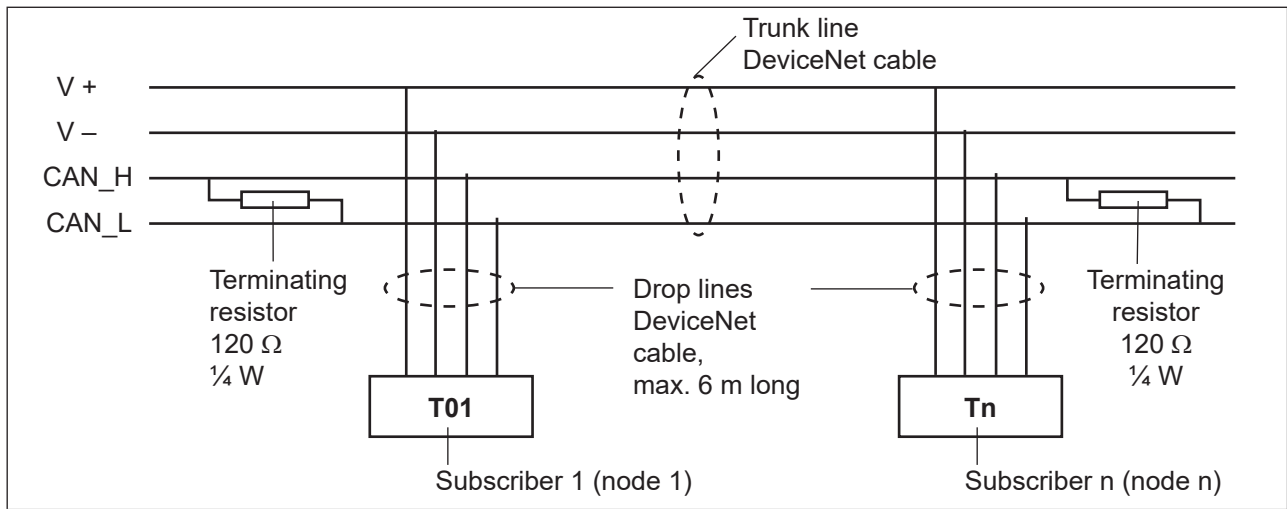

Fig. 29: Network topology

10.10. Configuration of the DeviceNet address/baud rate

8 DIP switches are available for configuration:

- DIP switches 1 to 6 for the DeviceNet address
- DIP switches 7 to 8 for the baud rate

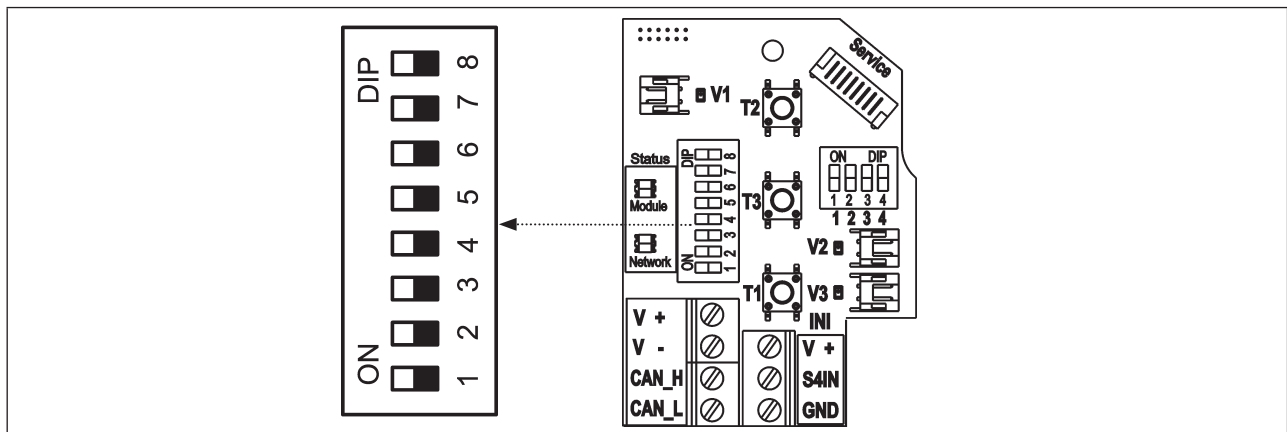

Fig. 30: Position of the DIP switches for baud rate and addressing on the electronic module



10.10.1. Setting of the DeviceNet address

MAC ID address = Medium Access Control Identifier Address

MAC ID address = $[DIP\ 1 \cdot 2^0 + DIP\ 2 \cdot 2^1 + DIP\ 3 \cdot 2^2 + DIP\ 4 \cdot 2^3 + DIP\ 5 \cdot 2^4 + DIP\ 6 \cdot 2^5]$

with DIP x = off = 0 and DIP x = on = 1

Table of the settings of the DeviceNet address:

MAC ID	DIP1	DIP2	DIP3	DIP4	DIP5	DIP6
0	off	off	off	off	off	off
1	on	off	off	off	off	off
2	off	on	off	off	off	off
3	on	on	off	off	off	off
4	off	off	on	off	off	off
5	on	off	on	off	off	off
6	off	on	on	off	off	off
7	on	on	on	off	off	off
8	off	off	off	on	off	off
9	on	off	off	on	off	off
10	off	on	off	on	off	off
11	on	on	off	on	off	off
12	off	off	on	on	off	off
13	on	off	on	on	off	off
14	off	on	on	on	off	off
15	on	on	on	on	off	off
16	off	off	off	off	on	off
17	on	off	off	off	on	off
18	off	on	off	off	on	off
19	on	on	off	off	on	off
20	off	off	on	off	on	off
21	on	off	on	off	on	off
22	off	on	on	off	on	off
23	on	on	on	off	on	off
24	off	off	off	on	on	off
25	on	off	off	on	on	off
26	off	on	off	on	on	off
27	on	on	off	on	on	off
28	off	off	on	on	on	off
29	on	off	on	on	on	off
30	off	on	on	on	on	off
31	on	on	on	on	on	off

MAC ID	DIP1	DIP2	DIP3	DIP4	DIP5	DIP6
32	off	off	off	off	off	on
33	on	off	off	off	off	on
34	off	on	off	off	off	on
35	on	on	off	off	off	on
36	off	off	on	off	off	on
37	on	off	on	off	off	on
38	off	on	on	off	off	on
39	on	on	on	off	off	on
40	off	off	off	on	off	on
41	on	off	off	on	off	on
42	off	on	off	on	off	on
43	on	on	off	on	off	on
44	off	off	on	on	off	on
45	on	off	on	on	off	on
46	off	on	on	on	off	on
47	on	on	on	on	off	on
48	off	off	off	off	on	on
49	on	off	off	off	on	on
50	off	on	off	off	on	on
51	on	on	off	off	on	on
52	off	off	on	off	on	on
53	on	off	on	off	on	on
54	off	on	on	off	on	on
55	on	on	on	off	on	on
56	off	off	off	on	on	on
57	on	off	off	on	on	on
58	off	on	off	on	on	on
59	on	on	off	on	on	on
60	off	off	on	on	on	on
61	on	off	on	on	on	on
62	off	on	on	on	on	on
63	on	on	on	on	on	on

10.10.2. Setting the baud rate

Adjustment of the device to the baud rate of the network (see “Fig. 30” on page 59).

Baud rate	DIP 7	DIP 8
125 kBit/s	off	off
250 kBit/s	on	off
500 kBit/s	off	on
not permitted:	(on)	(on)



If the settings are changed by actuating the DIP switches, this change will not take effect until the device is restarted!

For a restart:

- briefly disconnect the device from the power supply and reconnect or
- switch the power supply off/on or
- transmit an appropriate reset message.

10.11. Configuration of the process data

To **transmit process data** via an I/O connection, 1 static input and 1 static output assembly are available. These assemblies contain selected attributes combined into one object so that process data can be transmitted collectively via an I/O connection.

The **process data** is selected by setting the device parameters Active Input Assembly and Active Output Assembly or - if supported by the DeviceNet-Master/Scanner - by setting Produced Connection Path and Consumed Connection Path when an I/O connection is initialized according to the DeviceNet specification.

10.11.1. Static input assembly

Name	Address of data attribute of the assembly for read access. Class, instance, attribute	Format of the data attribute Value 0: OFF, Value 1: ON
Sensor state, valve state	4, 1, 3	<p>Byte 0:</p> <p><u>Bit 0 - 3: position sensor state:</u></p> <p>Bit 0: S1 Bit 1: S2 Bit 2: S3 Bit 3: S4</p> <p>(Bit 0 - 3 = 0, if process valve type “D4” , “DA4” or “D4SL” selected)</p> <p><u>Bit 4 – 7: valve state:</u></p> <p>(see below)</p>



Name	Address of data attribute of the assembly for read access. Class, instance, attribute	Format of the data attribute Value 0: OFF, Value 1: ON
Sensor state, valve state	4, 1, 3	<p><u>Bit 4 – 7: valve state:</u></p> <ul style="list-style-type: none"> Bit 4: closed Bit 5: open Bit 6: upper seat lift Bit 7: lower seat lift <p>(Bit 4 - 7 = 0, if process valve type "D4PMO" selected)</p> <p>For process valve type selection refer to chapter "5.5".</p>

The address listed in the table above ("Static input assembly") can be used as path data for the Produced Connection Path attribute of an I/O connection.

Nevertheless, by using this address data, the attributes combined in the assemblies can also be accessed acyclically via Explicit Messages.

10.11.2. Static output assembly

Name	Address of data attribute of the assemblies for read access. Class, instance, attribute	Format of the data attribute Value 0: OFF, Value 1: ON
Pilot valves V1...3	4, 21, 3	<p>Byte 0:</p> <ul style="list-style-type: none"> Bit 0: Pilot valve V1 Bit 1: Pilot valve V2 Bit 2: Pilot valve V3 Bit 3...7: not used

The address listed in the table above ("Static output assembly") can be used as path data for the Produced Connection Path attribute of an I/O connection.

Nevertheless, by using this address data, the attributes combined in the assemblies can also be accessed acyclically via Explicit Messages.

10.11.3. Logic tables for the valve D4 series

The following logic tables work internally in the device, the combination of the single (target) signals S1-S4 results in the final signal for the valve state or sensor state for SPX D4PMO (indicated with the device status LED/Top LED).

The combination of the target signals S1-S4 for a special valve state depends on the valve type - see the following tables:



Logic tables for SPX D4:

valve state	linear sensor 2 (teach data) (external position sensor)		linear sensor 1 (teach data) (internal position sensor)	
	S1	S2	S3	S4
closed	1	0	1	0
open	0	0	0	1

Static input assembly (class, instance, attribute: 4, 1, 3)		Format of the data attribute Value 0: OFF, Value 1: ON
Byte 0: Bit 0	sensor state	0 (not used)
Bit 1		0 (not used)
Bit 2		0 (not used)
Bit 3		0 (not used)
Bit 4	valve state	closed
Bit 5		open
Bit 6		0 (not used)
Bit 7		0 (not used)

Static output assembly (class, instance, attribute: 4, 21, 3)	Pilot V1 (main stroke)
Byte 0: Bit 0	1
Bit 1	0
Bit 2	0
Bit 3 - 7	not used

Logic tables for SPX DA4:

valve state	linear sensor 2 (teach data) (external position sensor)		linear sensor 1 (teach data) (internal position sensor)	
	S1	S2	S3	S4
closed	1	0	0	0
open	0	0	0	1
upper seat lift	0	1	0	0
lower seat lift	1	0	1	0

Static input assembly (class, instance, attribute: 4, 1, 3)		Format of the data attribute Value 0: OFF, Value 1: ON
Byte 0:		
Bit 0	sensor state	0 (not used)
Bit 1		0 (not used)
Bit 2		0 (not used)
Bit 3		0 (not used)
Bit 4	valve state	closed
Bit 5		open
Bit 6		upper seat lift
Bit 7		lower seat lift

Static output assembly (class, instance, attribute: 4, 21, 3)	Pilot V1 (main stroke)	Pilot V2 (upper seat lift)	Pilot V3 (lower seat lift)
Byte 0:			
Bit 0	1	0	0
Bit 1	0	1	0
Bit 2	0	0	1
Bit 3 - 7	not used		



Logic tables for SPX D4SL:

valve state	linear sensor 2 (teach data) (external position sensor)		linear sensor 1 (teach data) (internal position sensor)	
	S1	S2	S3	S4
closed	1	0	1	0
open	0	0	0	1
upper seat lift	0	1	1	0
lower seat lift	1	0	0	0

Static input assembly (class, instance, attribute: 4, 1, 3)		Format of the data attribute Value 0: OFF, Value 1: ON
Byte 0:		
Bit 0	sensor state	0 (not used)
Bit 1		0 (not used)
Bit 2		0 (not used)
Bit 3		0 (not used)
Bit 4	valve state	closed
Bit 5		open
Bit 6		upper seat lift
Bit 7		lower seat lift

Static output assembly (class, instance, attribute: 4, 21, 3)	Pilot V1 (main stroke)	Pilot V2 (upper seat lift)	Pilot V3 (lower seat lift)
Byte 0:			
Bit 0	1	0	0
Bit 1	0	1	0
Bit 2	0	0	1
Bit 3 - 7	not used		



Logic tables for SPX D4PMO:

The static input assembly (class, instance, attributes 4, 1, 3) of the control unit for this valve type is the sensor signal of the taught position, not the valve state - see the following tables.

The valve state combination table must be implemented in the PLC software.

The opposite valve stem remains in “closed position” during seat lifting - this can be monitored by observing the corresponding sensor position signal.

Valve state	linear sensor 2 (teach data) (external position sensor)		linear sensor 1 (teach data) (internal position sensor)	
	S1	S2	S3	S4
closed	1	0	1	0
open	0	0	0	1
upper seat lift	0	1	1	0
lower seat lift	1	0	0	0

Static input assembly (class, instance, attribute: 4, 1, 3)		Format of the data attribute Value 0: OFF, Value 1: ON
Byte 0:		
Bit 0	sensor state	S1
Bit 1		S2
Bit 2		S3
Bit 3		S4
Bit 4	valve state	0 (not used)
Bit 5		0 (not used)
Bit 6		0 (not used)
Bit 7		0 (not used)

Static output assembly (class, instance, attribute: 4, 21, 3)	Pilot V1 (main stroke)	Pilot V2 (upper seat lift)	Pilot V3 (lower seat lift)
Byte 0:			
Bit 0	1	0	0
Bit 1	0	1	0
Bit 2	0	0	1
Bit 3 - 7	not used		

10.12. Configuration of the device

10.12.1. Configuration of the safety position of pilot valves during a bus error

The *valve safety position* and the *safety mode* attributes can be used to configure the pilot valves in the event of a bus error.

The configuration data of the (behaviour of) pilot valves in case of a bus error can be accessed acyclically via Explicit Messages.

- The *Get_Attribute_Single* service stands for a **read access** of the configuration data.
- The *Set_Attribute_Single* service stands for a **write access** of the configuration data.

1 data byte for **safety mode**:
(attribute address:
class 150, instance 1, attribute 7)

Bit	Mode	Value assignment
Bit 0	Charac- teristics in event of bus error	0 Approach safety position
		1 Retain last valve position
Bits 1...7	not used	0 (always)

1 data byte for **valve safety position**:
(attribute address:
class 150, instance 1, attribute 6)

Value	Pilot valve 1	Pilot valve 2	Pilot valve 3
0	OFF	OFF	OFF
1	ON	OFF	OFF
2	OFF	ON	OFF
3	OFF	OFF	ON



NOTE!

Maximum one pilot valve can be switched **ON** in safety position at the same time!

10.12.2. Configuration example

The example describes the principle procedure when configuring the device using the RSNetWorx software for DeviceNet (revision V.24.00).

Installation of the EDS File:

The EDS file is installed with the aid of the EDS Installation Wizard Tool associated with RSNetWorx. During the installation procedure the icon can be assigned (if this does not occur automatically).

Offline parameterization of the device:

When a device has been inserted into the DeviceNet configuration of RSNetWorx, the device can be parameterized offline.

“Fig. 31” indicates how, for example, the process valve safety position which deviates from the factory setting can be selected.

For the D4 valves series is only one input assembly available – explained in “10.11.1. 5



All parameter changes implemented offline must become operative for the real device at a later date by a download process.

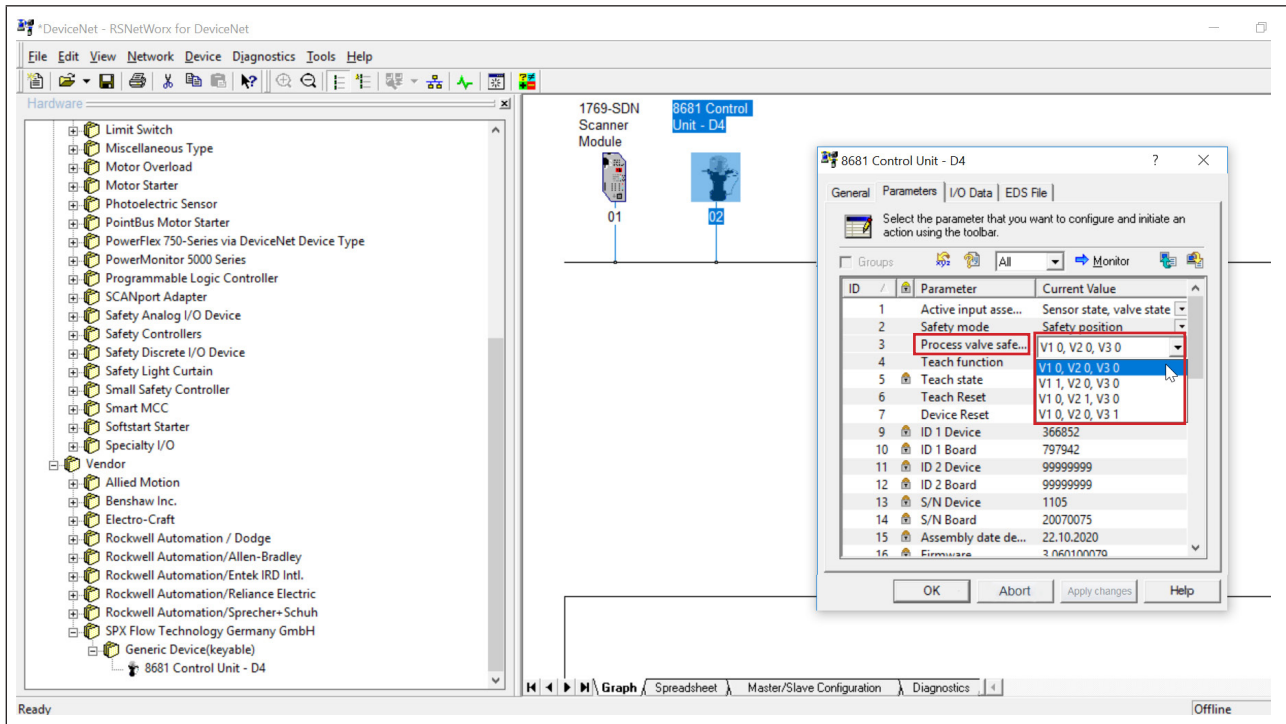

Fig. 31: Selecting, for example, the Process valve safety position (screenshot)

Online parameterization of the device:

Devices can also be parameterized online. In doing so, you can also select whether only individual parameters (single) or all parameters (all) of a group are read from the device (upload) or are loaded into the device (download).

It is also possible to transfer individual parameters or all parameters of a group cyclically in monitor mode. This may be helpful particularly for start-up purposes.

10.12.3. EDS description

The DeviceNet parameters are listed in a table in the [“21. Appendix - EDS description”](#) on page 93

10.13. Display of the status LEDs in the event of a bus error



The bus errors are also indicated by the central multi-colour status display (device status LED / Top LED) - see chapter ["13.2. Blinking pattern & fault signaling"](#).

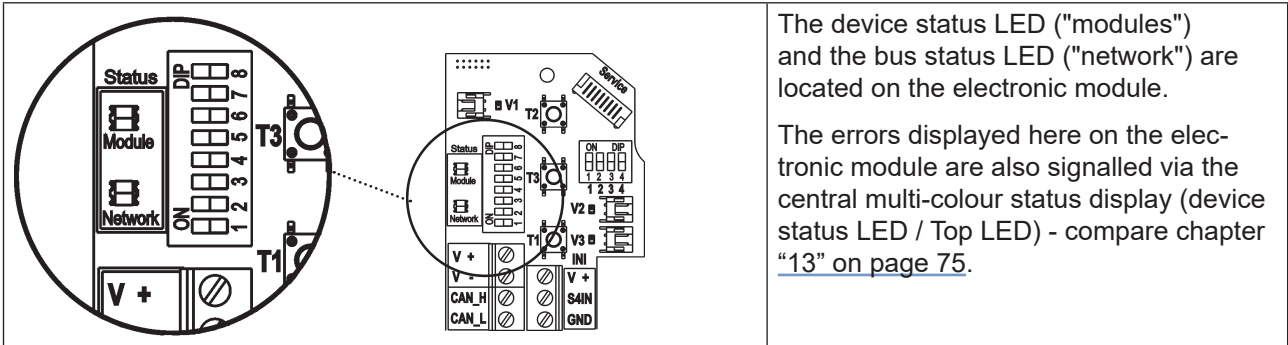

The device status LED ("modules") and the bus status LED ("network") are located on the electronic module.

The errors displayed here on the electronic module are also signalled via the central multi-colour status display (device status LED / Top LED) - compare chapter ["13"](#) on page 75.

Fig. 32: Status LEDs

Function tests for both status LEDs after power has been switched on (connection of the network cable):

Status LED	Colours of the LED	Function test
"Modules"	green / red	<ul style="list-style-type: none"> • 250 ms ON (green) • 250 ms ON (red)
"Network"	green / red	<ul style="list-style-type: none"> • 250 ms ON (green) • 250 ms ON (red)

When the test is complete, the status LEDs indicate the device states which are described in the following tables (["10.13.1"](#), ["10.13.2"](#)).

10.13.1. Status of the device status LED "Modules"

LED	Device state	Explanation
Off	No supply	Device is not supplied with voltage
Green	Device is working	Normal operating state
Flashes red		<p>The DIP switch setting for the baud rate or the MAC ID address has been changed and does not correspond to the value read during the last device restart.</p> <p>The change will not be applied until the next device restart.</p>



10.13.2. State of bus status LED "Network"

LED	Device state	Explanation	Troubleshooting
Off	No voltage / not online	<ul style="list-style-type: none"> • Device is not supplied with voltage • Device has still not ended Duplicate MAC ID Test (test lasts approx. 2 s) • Device cannot end Duplicate MAC ID Test. 	<ul style="list-style-type: none"> • Connect other devices, if the device is the only network subscriber, • replace device • check baud rate • check bus connection
Green	Online, connection to master exists	<ul style="list-style-type: none"> • Normal operating state with established connection to the master 	
Flashes green	Online, without connection to master	<ul style="list-style-type: none"> • Normal operating state without established connection to the master 	
Flashes red	Connection time-out	<ul style="list-style-type: none"> • One or more I/O connections are in Time-Out state 	<ul style="list-style-type: none"> • New connection establishment by master to ensure that the I/O data is transmitted cyclically.
Red	Critical fault	<ul style="list-style-type: none"> • Another device with the same MAC ID address is in the circuit • No bus connection due to communication problems 	<ul style="list-style-type: none"> • Check baud rate • Please check address as possible troubleshooting • If required, replace device

11. POSITION MEASURING SYSTEM / INDUCTIVE POSITION SENSORS

11.1. Operating principle of the position measuring system

The position measurement is based on recording the change in position of two ferromagnetic targets inside the device, which are independent from each other. The geometry and the material of the targets to be used are synchronized with the sensitivity of the system.

The measurement precision is determined by the ferromagnetic properties of the targets and all other parts in the system. While the targets must be ferromagnetic, the other components are ideally made of materials that do not have ferromagnetic properties – see therefor chapter [“4.6. Data of position sensors”](#).

The state (switching positions) of the process valve and also of the valve seats are reported to the higher-level control by feedback signals from the two inductive position sensors. The connection to the device is done by means of a simple adaptation to the process valve shaft (see also chapter [“5. Assembly”](#) on page 26).

11.2. Stroke range / feedback signals

The recordable stroke range for the

- internal position sensor (for target positions S3 + S4) is between 0 ... 80 mm,
- external position sensor (for target positions S1 + S2) is between 0 ... 40 mm.

4 discrete feedback signal are evaluated:

- Target position 1
- Target position 2
- Target position 3
- Target position 4

The valve state results from a combination of the target positions S1... S4. See therefor the respective “logic tables”

for 24 V DC design: [“8.6. Logic tables for the valve D4 series”](#) on page 40 or

for AS-i design: [“9.9.2. Logic tables for the valve D4 series”](#) on page 50 or

for DeviceNet: [“10.11.3. Logic tables for the valve D4 series”](#) on page 62.

The target positions are reported within a certain feedback field which can be adapted - see chapter [“4.7.1. Feedback fields \(tolerance band\) of the position sensors”](#) on page 23.

12. TEACH PROCEDURE

12.1. Teach buttons / Teach functions

To indicate the valve and seat positions or switching states via the Top LED, the position of the valve and seat must be recorded via the targets of the two position sensors.

To teach the corresponding target positions for “valve closed/open” and “upper/lower seat lift”, an Autotune function is used - described below.

For special applications (performed only by service personnel) the teach procedure can be done manually - described in chapter “12.3. Manual teach procedure”.

On the electronic module inside the device are three Teach buttons T1 ... T3 to start the teach procedure or to reset the taught target positions. The Teach buttons are accessible after removing the housing of the device (see chapter “6. Opening and Closing the Housing”).

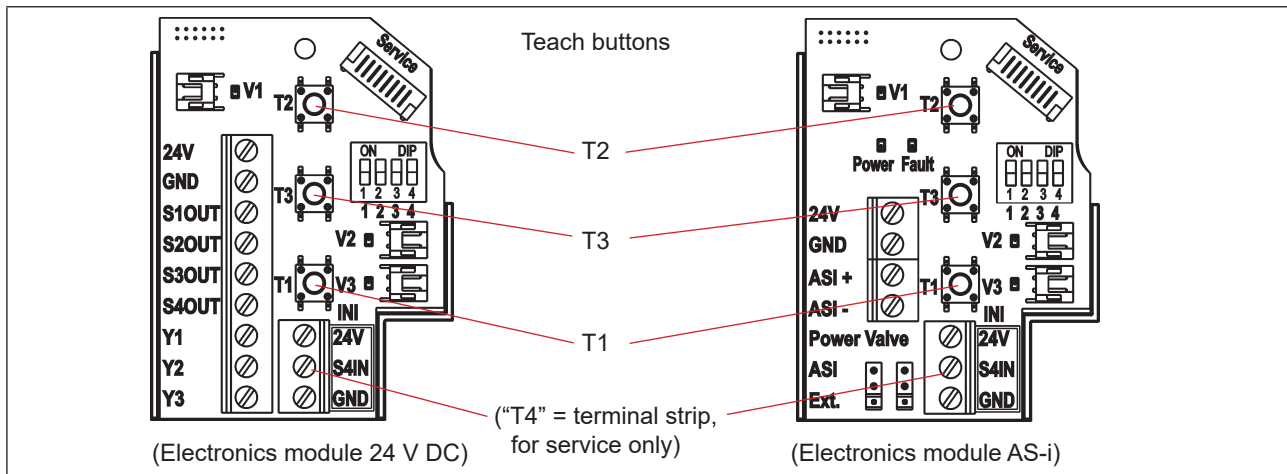

Fig. 33: Teach buttons on the electronic modules (in the example of the electronic modules for 24 V DC and AS-i)

12.2. Autotune function

12.2.1. Autotune mode / Autotune function

- Ensure that the **pneumatic connections** have been made correctly, considering: A1 = V1 | A2 = V2 | A3 = V3, compare chapter “7.2. Pneumatic connection of 8681 Control Unit - D4” on page 34
- Ensure that **control air** is supplied
- Open the housing following the instructions in chapter “6. Opening and Closing the Housing”.
- **Electrical power** has to be switched on (for the function of position measuring system and Top LED).
- Ensure that the **valve type** is correctly set via DIP switches DIP3+4 (see “5.5. Selection of the process valve type (D4 series)” on page 30).
- Ensure that **process valve is at closed position** before starting the Autotune mode and function.
- **First start the Autotune mode** by pressing the buttons T2+T3 simultaneously for minimum 2.5 seconds.



→ Then start the Autotune function by pressing button T1 for ca. 0.5 seconds. (If the Autotune function has not been started 10 seconds after the change to Autotune mode, that mode will be exited.)

Teach button	Activation duration	Mode	Optical feedback		Teach button	Activation duration	Function	Optical feedback
T2 + T3	2.5 s	to start Autotune mode	red + yellow + green flashing sequentially (500 ms per colour)	+	T1	0.5 s	to start Autotune function	red + yellow + green flashing sequentially (200 ms per colour)

The Autotune function starts now the automatic teach procedure which is described in detail in "12.2.2".

→ If required, return the device and system to normal operating state (switching position, power supply).

→ Close the housing following the instructions in chapter "6. Opening and Closing the Housing".



If the Autotune function does not run properly or is aborted (if e.g. no compressed air is connected), the target positions already taught are deleted again, the Autotune function is left and switched to normal operation. The target positions (S1 ... S4) are set to "not taught", i.e. the Top LED blinks in the fault colour.

12.2.2. Autotune function process

There is *one* autotune function. Depending on which process valve of the D4 series is used or selected (see chapter "5.5" on page 30), the autotune process will last differently:

Autotune function / procedure:

Control	Effect on the process valve	Internal program	Error
T2 + T3	Autotune mode starts		
T1	Autotune function starts		
	Start at closed position	Teach respective target position(s)	
	To open valve	Activate pilot valve 1	
		Wait period 10 s (+ 5 s*)	
	To teach open position	Teach respective target position(s)	
	To close valve	Deactivate pilot valve 1	
	Valve closes	Wait for closed position	Timeout 15s
Autotune function and mode completed if D4 valve type was connected - otherwise it continues with:			
	To bring upper seat in position	Activate pilot valve 2	
		Wait period 10 s (+ 5 s*)	
	To teach upper seat lift position	Teach respective target position(s)	
	To close upper seat	Deactivate pilot valve 2	
		Wait for closed position	Timeout 15s
	To bring lower seat in position	Activate pilot valve 3	
		Wait period 10 s (+ 5 s*)	
	To teach lower seat lift position	Teach respective target position(s)	
		Check process valve selection	Wrong process valve selection via DIP switch
	To close lower seat	Deactivate pilot valve 3	
		Wait for closed position	Timeout 15s
Autotune function and Autotune mode completed			

*) additional dynamic timeout, in case process valve movement was detected after 10 s timeout



In the event that a timeout occurs (after 15 seconds wait period) or a **wrong process valve selection** via DIP switch 3+4 was detected, the corresponding Autotune function will be exited and switched to normal operation.

Furthermore, the Teach positions are set to "not taught", i.e. the Top LED blinks in the fault colour - see chapter "[13.2. Blinking pattern & fault signaling](#)" and "[15.5. Malfunctions](#)" on page 81.

The autotune mode and function can also be activated in the same way via the PC service programm, therefor interconnect the device with the PC via the Service interface connection (see "[Fig. 33](#)").

12.2.3. Autotune reset (Teach reset)

The Teach buttons can be used to reset the positions already taught by the autotune function:

→ To activate the **Teach reset**, press the buttons T1+T2 simultaneously for minimum 2.5 seconds (therefor you needn't to be in Autotune mode).

T1 + T2	2.5 s	Teach reset of all valve positions (S1, S2, S3 and S4)	Blinks in the fault colour (no position taught) - see chapter " 13.1 "
---------	-------	--	--

The setting of the **colour combination** for the valve and seat states are described in chapter "[13.1. Setting the colour combinations](#)".

Also the "blinking patterns" for valve/seat positions and fault feedback are described in chapter "[13.2. Blinking pattern & fault signaling](#)".

12.3. Manual teach procedure

The individual valve positions can be taught **manually** via the Teach buttons and these valve positions can be also reset (Teach reset - see chapter "[12.2.3](#)").



The **manual teach procedure** should **only** be carried out under defined conditions **by trained personnel**. **The production process must not be disturbed**. If a device is exchanged under production conditions and therefore a teach procedure is necessary, the positions may only be taught if the process valve is in the defined position - see "[Table 2: Teach buttons functions for manual teach procedure](#)".

Procedure:

- Ensure that the **pneumatic connections** have been made correctly, considering: A1 = V1 | A2 = V2 | A3 = V3, compare chapter "[7.2. Pneumatic connection of 8681 Control Unit - D4](#)" on page 34
- Ensure that **control air** is supplied
- Open the housing following the instructions in chapter "[6. Opening and Closing the Housing](#)".
- **Electrical power** has to be switched on (for the function of position measuring system and Top LED).
- Ensure that the **valve type** is correctly set via DIP switches DIP3+4 (see "[5.5. Selection of the process valve type \(D4 series\)](#)" on page 30).
- If the production process will not be disturbed and if the **process valve / seat** is not in the **right position** activate the process valve / seat to bring it in the defined position for the teach procedure



Teach procedure

This may occur via the pilot valves 1 to 3 (to be seen in “Fig. 1” on page 12) which can be activated via hand lever (see “Fig. 18” on page 36). The functionality of each pilot valve (V1 to V3) is described in the table in chapter “12.2.2” on page 72 or observe when the valve/seat is in the right position and follow next step(s):

- If the **process valve / seat** is in a defined position, **press the appropriate Teach button** (see “Table 2”) for approx. 1.5 seconds.
Teach button “T4” is realised using the terminal strip (with the connections S4IN and 24 V / V+)
- If required, return the device and system to normal status (switching position, power supply).
- Close the housing following the instructions in chapter “6. Opening and Closing the Housing”.

Teach button	Function	Activation duration	Optical feedback	Remarks
T1	manual teach function for closed position	1.5 s	TOP LED pauses and flashes quickly during teach process, then continuously in the encoded colour for the taught position.	
T2	manual teach function for open position	1.5 s		
T3	manual teach function for upper seat lift	1.5 s		Not available, if valve type D4 selected by DIP switches 3, 4 (see chapter “5.5”).
“T4” = S4In (for service only)	manual teach function for lower seat lift	1.5 s		No check of right process valve selection via DIP switches 3, 4 during teach process. Terminal strip: connection S4IN needs to be externally connected to 24V / V+ for activation duration.
T1 + T2	Teach reset of all valve positions	2.5 s		Flashes in the fault colour – see chapter “13.1”

Table 2: Teach buttons functions for manual teach procedure

13. LED COLOUR ASSIGNMENTS

The switching states of the process valves as well as the device states are signalled to the outside via the central multi-colour status display (device status LED / Top LED), so that quick visual control is possible also for large systems.

Colours and blinking patterns have been assigned to the signals of the process valve positions and device states – see chapter “13.1. Setting the colour combinations” and “13.2. Blinking pattern & fault signaling”.

In order to be able to react to different process valve designs or customer signaling philosophies in the systems, the colour assignments can be individually configured on site by means of the switches **DIP1 and DIP2 for colour coding**, see below “13.1. Setting the colour combinations”.

The DIP switches **DIP3 and DIP4 are used to set the valve type** – see chapter “5.5. Selection of the process valve type (D4 series)” on page 30.

Delivered state: **DIP1 - 3:** position 0 = **OFF** and
DIP4: position 1 = **ON**

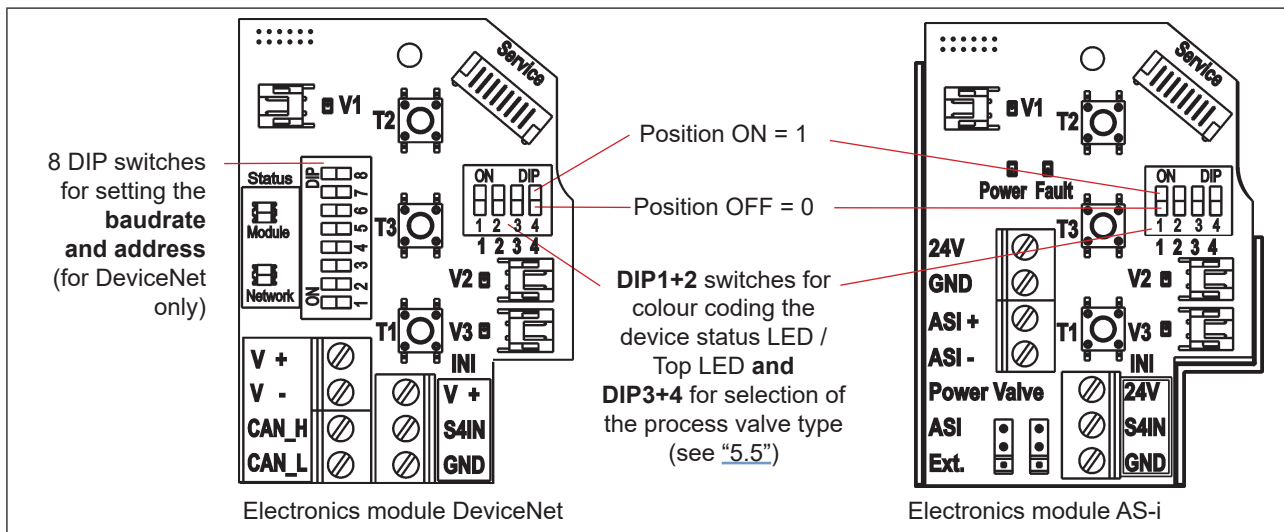

Fig. 34: DIP switches for setting the colour coding (in the example of the electronic modules for DeviceNet and AS-i)

13.1. Setting the colour combinations







The setting of the possible colour combinations for the indication of the state of process valve and valve seats with the help of the DIP switches **DIP1 and DIP2:**

Valve closed	Valve open	Upper seat lift	Lower seat lift	Fault	DIP1	DIP2
steady green	steady yellow	Fast flashing yellow	Slow flashing yellow	red	0	0
steady yellow	steady green	Fast flashing green	Slow flashing green	red	1	0
steady green	steady red	Fast flashing red	Slow flashing red	yellow	0	1
steady red	steady green	Fast flashing green	Slow flashing green	yellow	1	1

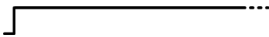

13.2. Blinking pattern & fault signaling

The device status LED / Top LED flashes in different "blinking patterns" in the event of a fault or in various states:

Blinking patterns	ON	OFF	Note
	ON		permanent lighting in the respective colour for valve state "valve closed" or "valve open"
	100 ms	100 ms	Flashes three times in the colour of the valve state to confirm the teaching of a target position Flashes three times in the corresponding fault colour : - if target could not be located in the measuring area during teaching or - if teach position is too close (± 0.5 mm) to a previously defined teach position or - if magnetic manual control is used, even though manual control function was disabled by software
 (fast flashing)	125 ms	125 ms	permanent flashing (in the colour for "valve open"): Signal for "upper seat lift"
 (slow flashing)	250 ms	250 ms	permanent flashing (in the colour for "valve open"): Signal for "lower seat lift" permanent flashing in the fault colour : - Teaching does not occur or - Autotune function error or - invalid signal from internal position sensor or - Teach Reset implemented or - Bus error or - Device Reset implemented
	450 ms	50 ms	permanent flashing in the fault colour : Internal Fault
	50 ms	450 ms	permanent flashing in the fault colour : Device in service mode/manual control active
	1 s	3 s	permanent flashing in the fault colour : Service/maintenance notification (maintenance / service required); Position feedback occurs during OFF phase

For troubleshooting see also chapter "15.5. Malfunctions" on page 81.

14. SERVICE MODE / MANUAL CONTROL

By default, the device provides (e.g. for service purposes) the following:

- a *magnetic manual control* which is easily accessible from the outside for Pilot Valve 1 (2/A1)¹⁾ as well as
- a *mechanical manual control* accessible when the hood is open on each equipped pilot valve – see chapter [“14.2. Mechanical manual control”](#).

14.1. Magnetic manual control

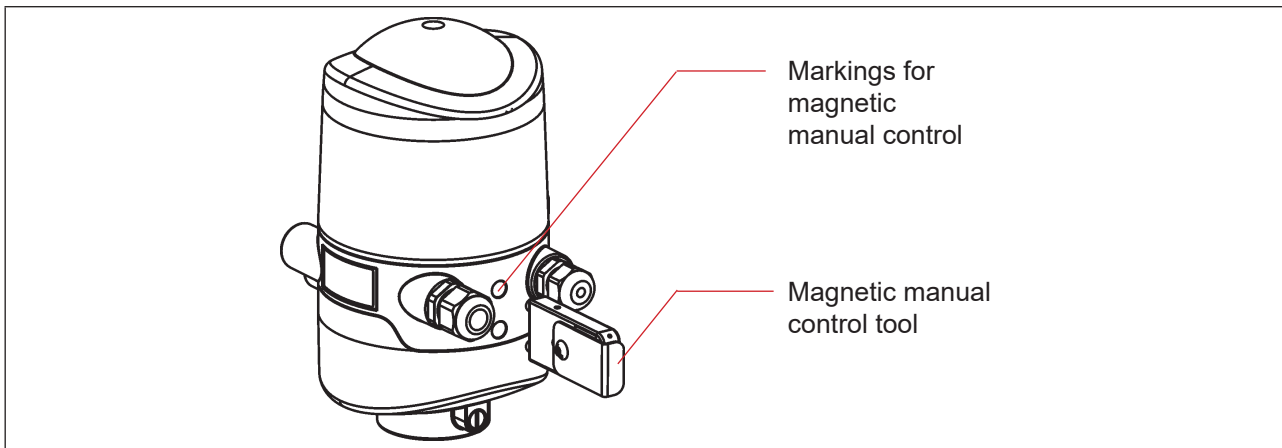

Fig. 35: Manual control on the basis of encoded magnetic fields

Irrespective of the signal of the higher-level control, in the Automatic operating mode the magnetic manual control sets the output of the pilot valve V1 electrically to an ON signal and, if control pressure is present, switches the 2/A1 output. The magnetic manual control cannot be used in manual operating mode.



However, if the output of pilot valve 1 is activated by the control (ON signal from the higher-level control), this switching state cannot be set to an OFF signal with the manual control!

Activation/deactivation of this function is possible using the PC service program. The factory setting is “magnetic manual control function active”, i.e. the function can be used, it is not disabled.

The connection to the PC is made via the service interface. Details are described in the “PC Service Program” software manual under the “SYSTEM/Start-up” menu option.



Caution!

When the magnetic manual control (for pilot valve V1) will be activated:

- the peripheral fault bit is set on the AS interface design,
- the mode is switched to "Manual control active" for the DeviceNet design and can be read out,
- the feedback signals (valve positions) function as per normal operation.

Always observe the safety guidelines and the system states!

The *activation of the magnetic manual control* or errors when using magnetic manual control are indicated by device status LED / Top LED – see chapter [“13.2. Blinking pattern & fault signaling”](#).

Procedure for activating & deactivating the magnetic manual control for pilot valve location 2/A1:

- Observe safety guidelines for the system prior to using the manual control!
- Activating the magnetic manual control (only possible in automatic operating mode):
Hold the magnetic manual control tool on the identification points between the cable glands for three seconds
(see “Fig. 35”),
feedback signal of the activation by device status LED / Top LED – see chapter “13.2. Blinking pattern & fault signaling”.
- Once the measure has been completed, deactivate the magnetic manual control:
Hold the manual control tool on the identification points between the cable glands for another three seconds (see “Fig. 35”).



After a power failure the magnetic manual control is reset and the device restarts in standard operating mode, i.e. the signal of the higher-level control is accepted.

14.2. Mechanical manual control

If additional manual controls are required for additional service purposes or in the event of a failure of the electrical energy, it is possible for all voltage and communication designs to switch the connected process valve using the mechanical manual control of the respective pilot valves V1 to V3 after opening the housing.

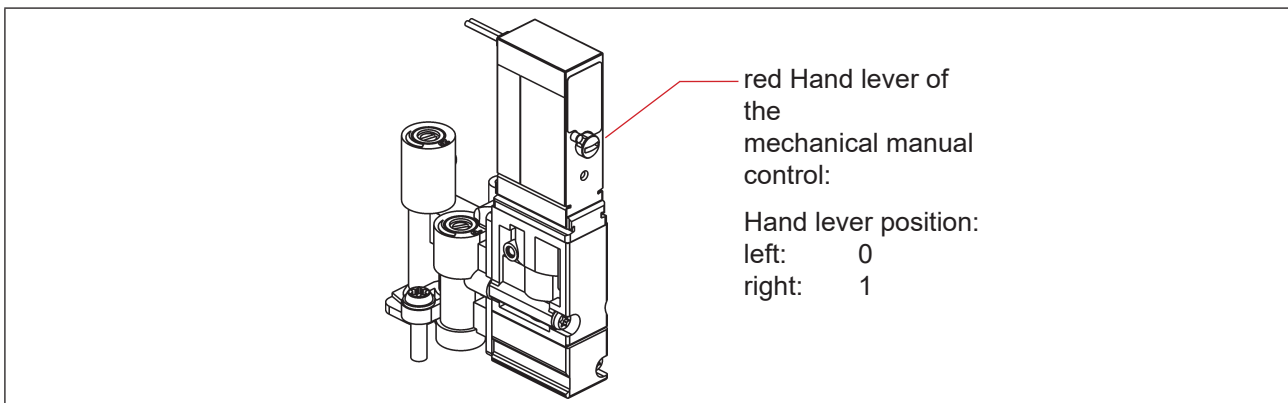

Fig. 36: Mechanical manual control of the pilot valves



When the service measures have been completed, reset all manual controls to "0" for controlled operation of the system!



15. MAINTENANCE / TROUBLESHOOTING

15.1. Safety instructions

DANGER!

Risk of injury due to electric shock!

- ▶ Before reaching into the system, switch off the power supply and secure it to prevent restarting!
- ▶ Observe applicable accident prevention and safety regulations for electrical equipment!
- ▶ When setting the position measuring system (Teach), do not contact any live components!

WARNING!

Risk of injury due to high pressure in the system!

- ▶ Before loosening lines and valves, turn off the pressure and vent the lines.

Risk of injury due to unintentional activation of the system and uncontrolled restart!

- ▶ Secure system against unintentional activation.
- ▶ Following assembly, ensure a controlled restart.

CAUTION!

Risk of injury due to improper maintenance!

- ▶ Maintenance may only be carried out by trained technicians and with the appropriate tools!

15.2. Safety positions

Safety positions of the pilot valves after failure of the electrical or pneumatic auxiliary power:

Operating mode	Process valve design	Safety positions after failure of the auxiliary power	
		electrical	pneumatic
	single-acting Control function A <ul style="list-style-type: none"> • air opening • spring closing 	down	down
	single-acting Control function B <ul style="list-style-type: none"> • air closing • spring opening 	up	up

If process valves with several switching positions (e.g. double-seated valves) are connected, the safety positions of the individual actuators can be viewed according to the same logic as for a classical single-seated valve.

Safety positions of the pilot valves after failure of the bus communication:

AS interface:

If the Watchdog is activated (default), behavior is the same as a failure of the auxiliary electrical power, i.e. all pilot valve outputs are set to "0".

DeviceNet:

See chapter ["10.12.1. Configuration of the safety position of pilot valves during a bus error"](#).

15.3. Maintenance / service

When used properly, the device operates maintenance and trouble-free.

For service work, please contact SPX Flow.

If the service/maintenance notification function is active (see chapter ["4.7. Factory settings in the firmware"](#)), a maintenance prompt is issued - indicated by a "blinking pattern" in the fault colour (1 s ON, 3 s OFF) - see chapter ["13.2. Blinking pattern & fault signaling"](#).

15.4. Cleaning

NOTE!

Aggressive cleaning agents may damage the material!

- The customary cleaning agents and foam cleaners can be used to clean the outside. We recommend checking that the cleaning agents are compatible with the housing materials and seals before using the cleaning agent.

→ Clean the device and rinse it thoroughly with clean water to safeguard against the formation of deposits in grooves and recesses.



If cleaning agent is not rinsed off properly, its concentration may considerably exceed the concentration for use when the water has evaporated. The chemical effect will thus be several times stronger!

Observe the specifications of the manufacturer and the recommendations for use of the cleaning agent manufacturer!

15.5. Malfunctions

In the event of any malfunctions in spite of a correct installation, proceed according to the fault analysis described in the table below. See also chapter [“13.2. Blinking pattern & fault signaling”](#) on page 76.

Fault description	Possible cause of the fault	Troubleshooting
Autotune procedure fails	Valve type selection via DIP switch DIP3, DIP4 does not comply with physical process valve	Check DIP switches for valve type selection - refer to chapter “5.5. Selection of the process valve type (D4 series)”
	Confused pneumatic connection lines	Check the correct pneumatic connection of the device to the process valve (for fluid diagrams see chapter “3.3.3. Fluid diagram” and the operating instructions of the corresponding process valves)
	No or insufficient pneumatic supply of the device	Check the pressure supply and ensure that supply is sufficient
	Manual flow restriction screws (for setting the flow-rate) set too tight, process valve still moves despite autotune timeout	Check the flow-rate via setting of the flow restriction screws - refer to “7.3. Flow restriction function of the pilot valves”
Autotune or manual teach procedure fails	Targets are not mounted on the process valve's shaft or target faulty	Check the target for correct mounting and condition (see chapter “4.6. Data of position sensors”).
	Two positions on the same position measuring system are too close to each other	Check correct process valve position

Fault description	Possible cause of the fault	Troubleshooting
No feedback signal	Position of the position sensors (Teach procedure) not appropriate for the shaft position (see "5.2")	Perform / repeat the Teach procedure (see chapter "12. Teach procedure")
	No or faulty associated feedback signals	Set the connections according to the pin and plug configurations described in these operating instructions (for the respective voltage / communication design).
	Targets are not mounted on the process valve's shaft or target faulty	Check the target for correct mounting and condition (see chapter "4.6. Data of position sensors").
Feedback signal is "lost" in system operation	Position in the limit range of the feedback field	Repeat the Teach procedure (see chapter "12. Teach procedure")
		Check the process valve end positions during operation against the end positions in non-operative state of the system.
		Check the pressure supply.
Valve output 2/A1 cannot be switched off with the control	Magnetic manual control is still activated	Deactivate the manual control - compare chapter "14.1. Magnetic manual control"
Valve outputs cannot be switched off by the control	Mechanical manual control at the pilot valve is still activated	Deactivate the mechanical manual controls on the pilot valves - compare chapter "14.2. Mechanical manual control"
Faults are signaled by means of device status LED / Top LED	Possible causes may vary depending on the version	Please read the corresponding descriptions of the respective communication design in these operating instructions (see also chapter)
No or faulty function of the process valves	No electrical power supply or communication for the device	Check the power supply and the communication settings (also refer to detailed descriptions of the respective designs in these operating instructions)
	No or insufficient pneumatic supply of the device	Check the pressure supply and ensure that supply is sufficient
Incorrect function of the process valves	Confused pneumatic connection lines	Check the correct pneumatic connection of the device to the process valve (for fluid diagrams see chapter "3.3.3. Fluid diagram" and the operating instructions of the corresponding process valves)
	Valves not correctly connected on electronic module	Check the correct electrical connection of the pilot valves - compare e.g. "Fig. 20: 24 V DC electronic module"



In the event of any undefined faults, be sure to contact the service department of SPX Flow

16. REPLACEMENT OF COMPONENTS AND MODULES

If components or modules need to be replaced for maintenance or service reasons, please observe the following notes and descriptions.

16.1. Safety instructions

DANGER!

Risk of injury due to electric shock!

- ▶ Before reaching into the system, switch off the power supply and secure it to prevent restarting!
- ▶ Observe applicable accident prevention and safety regulations for electrical equipment!

WARNING!

Risk of injury due to high pressure!

- ▶ Before loosening lines and valves, turn off the pressure and vent the lines.

Risk of injury due to unintentional activation of the system and uncontrolled restart!

- ▶ Secure system against unintentional activation.
- ▶ Following maintenance, ensure a controlled restart.

CAUTION!

Risk of injury due to improper maintenance!

- ▶ Maintenance may only be carried out by trained technicians and with the appropriate tools!

NOTE!

IP65 / IP67 protection

- ▶ During all work steps, make sure that IP65 / IP67 protection is once again ensured for the device when used as intended!

Opening and closing the device

- ▶ During all work which requires opening and closing of the device, also observe the notes and comments in chapter [“6. Opening and Closing the Housing”](#)!

16.2. Changing the electronic module

NOTE!

Electrostatic sensitive components/modules!

- The device contains electronic components which react sensitively to electrostatic discharge (ESD). Contact with electrostatically charged persons or objects may be hazardous to these components. In the worst case scenario, they will be destroyed immediately or will fail after start-up.
- Observe the requirements in accordance with DIN EN 61340-5-1 to minimize or avoid the possibility of damage caused by sudden electrostatic discharge!
- Also ensure that you do not touch electronic components when the supply voltage is on!

Removal procedure:

- Open the housing following the instructions in chapter “6. Opening and Closing the Housing”.
- If necessary, mark the electrical connections to ensure correct assignment during reinstallation!
- If necessary, note the set position of the 4 DIP switches (for colour code and valve type) and on the DeviceNet electronic module the DIP switches (8-switch block) for baud rate and address. On the AS-i electronic module, note the AS interface address and the jumper positions (power supply to AS interface).
- If required, read out and note special settings by the PC service program.
- Loosen all electrical connections on the electronic module (plug-type connections, screw-type terminal connections).
- Loosen the screw-type connection (Torx T10 screw) of the electronic module and store the screw in a safe place.
- Carefully press the electronic module forwards so that the contact pins on the internal position sensor are exposed.
- Carefully lift the electronic module upwards.

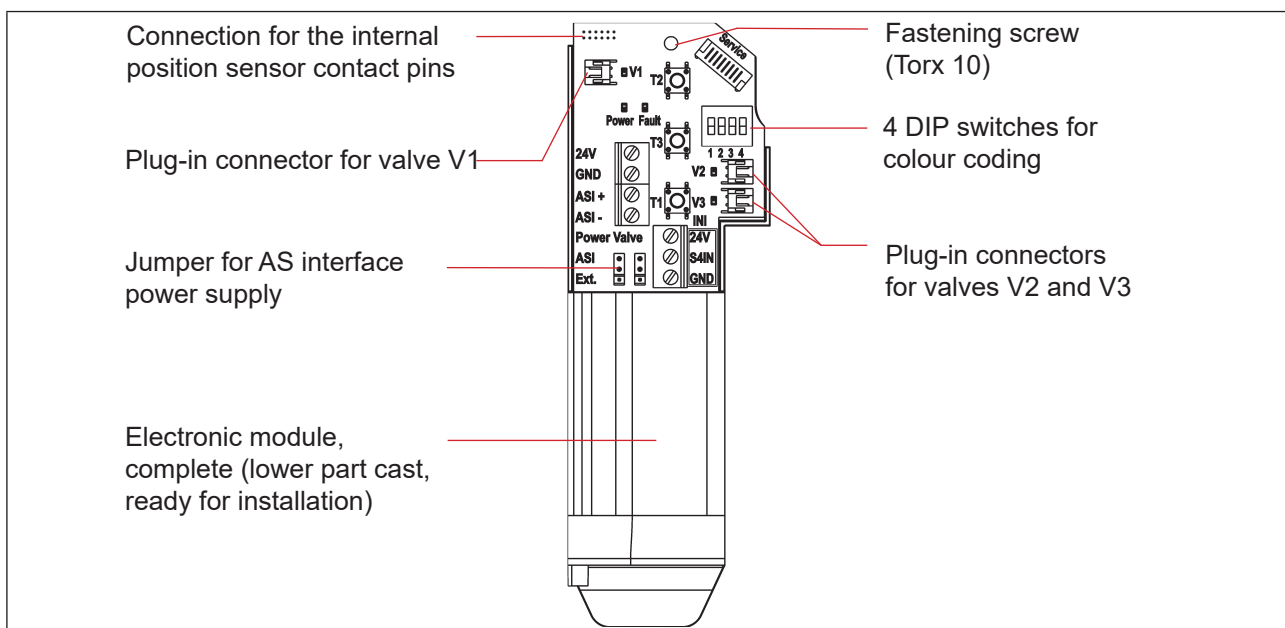

Fig. 37: Electronics module (here example of AS interface)

Installation procedure:

- Carefully insert the entire electronic module into the recess in the lower housing part.
- Plug the electronic module carefully onto the contact pins for the position measuring system.
- Refasten the electronic module with the Torx T10 screw (torque 0.4 Nm).
- Reattach the electrical connections.
- Check DIP switch positions (4-switch block for colour and valve type coding, 8-switch block on DeviceNet electronic module for address and Baud rate) and set the previously noted switch settings, if necessary.
- If necessary, set AS interface address and jumper positions.
- If required, make settings again, read out by the PC service program, using the PC service program.
- Perform Autotune procedure (see chapter [“12.2. Autotune function”](#) on page 71).



Be sure to work carefully and cautiously, so that the electronics are not damaged.

- Close the housing following the instructions in chapter [“6. Opening and Closing the Housing”](#).

16.3. Changing the valves (Type 6524)

According to the design, 1 or 3 pilot valves Type 6524 (V1 ... V3) have been installed in the device. The pilot valves have been designed with the flow restriction equipment for intake and exhaust air and must be installed as a valve module.

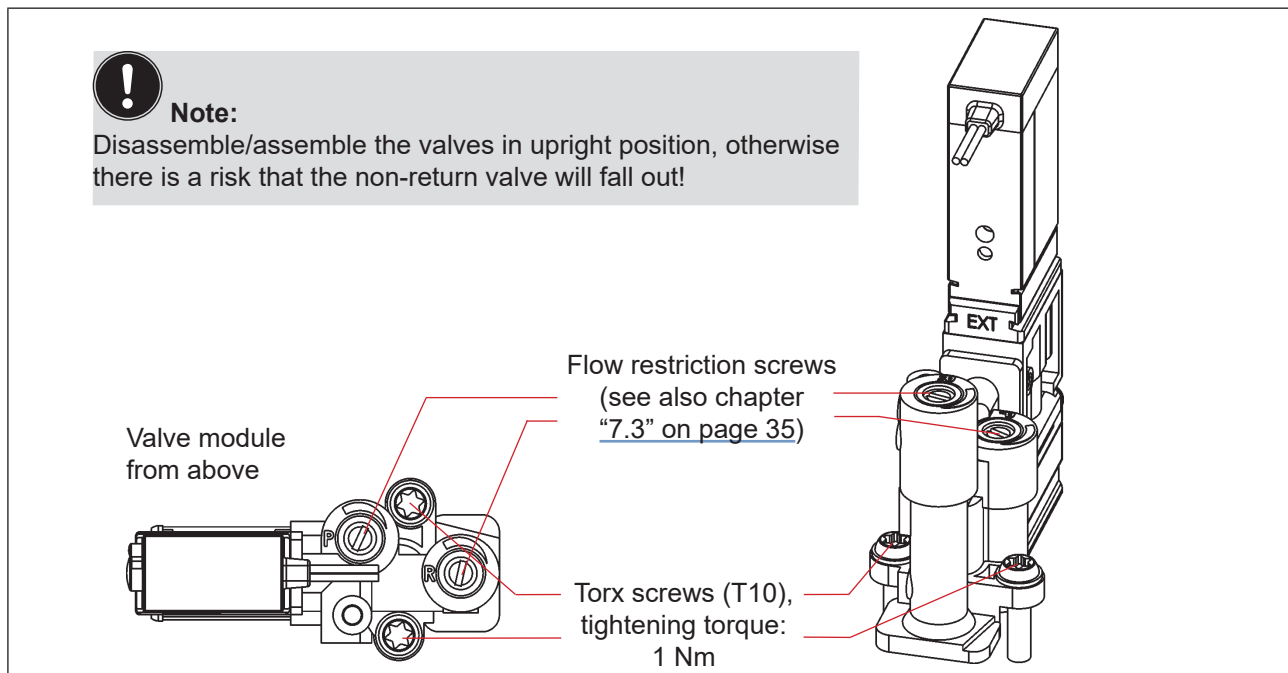

Fig. 38: Valve module Type 6524

Procedure:

- Open the housing following the instructions in chapter [“6. Opening and Closing the Housing”](#).
- If necessary, mark the electrical connections to ensure correct assignment during reinstallation.
- Loosen the electrical connections.
- Loosen the connecting screws (Torx T10) for the corresponding valve module.
- Take out the valve module and replace it with the spare part set.
- When inserting the valve module, make sure that the form seal fits correctly and fully on the lower side of the respective pilot valve flange!
- To fix the valve module: to do this, insert the screws (Torx T10) into the existing threading by turning them backwards and tighten them to a torque of 1.2 Nm.
- Reattach the electrical connections.
(If other connections, apart from the pilot valve connections, have been removed, read the corresponding chapters on the electrical installation of the respective voltage / bus / connection version)
- Adjust the flow restriction screws as described in chapter [“7.3. Flow restriction function of the pilot valves”](#) on page 35.
- Close the housing following the instructions in chapter [“6. Opening and Closing the Housing”](#).

16.4. Changing the internal position sensor

The internal position sensor consists of a housing, with a PCB mounted above with LEDs and light conductor. There are 4 snap-fit hooks, which secure the internal position sensor in the lower housing part, by snapping them into place.

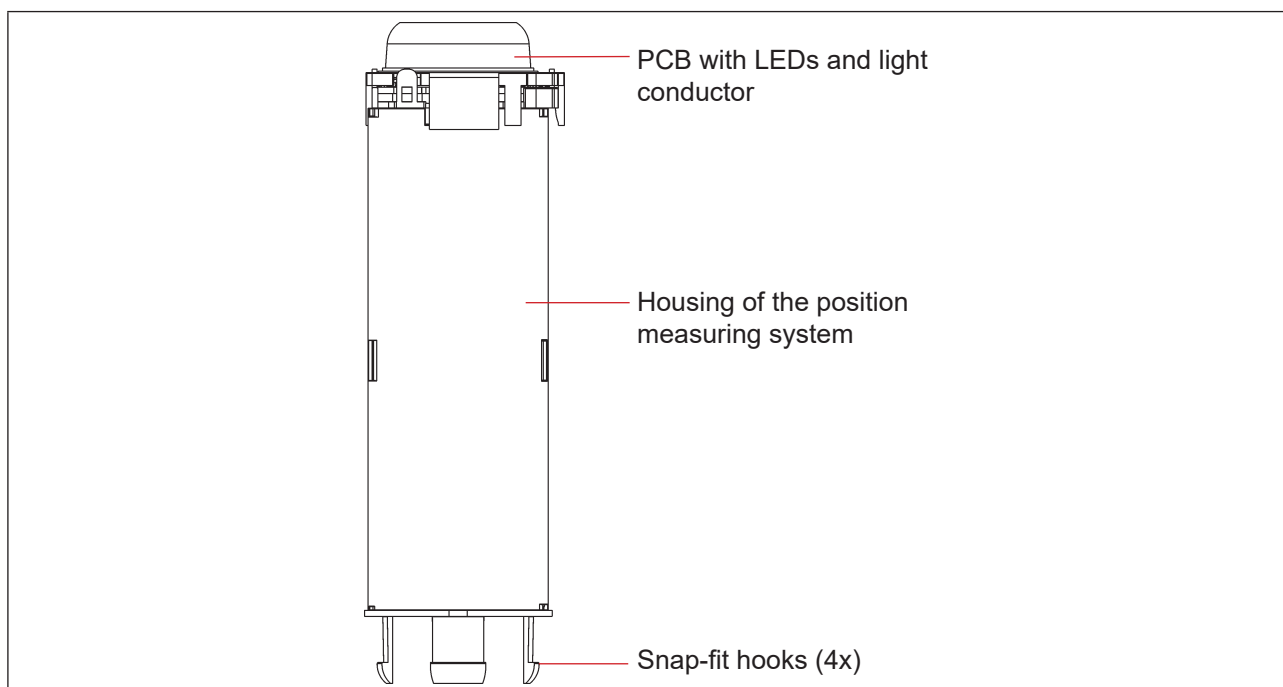

Fig. 39: Internal position sensor

WARNING!

Risk of injury due to high pressure!

- ▶ Before loosening lines and valves, turn off the pressure and vent the lines.

NOTE!

Electrostatic sensitive components/modules!

- Before changing the internal position sensor, switch the electrical power for the device off so that destruction of the PCB and electronic module is avoided.
- The device contains electronic components which react sensitively to electrostatic discharge (ESD). Contact with electrostatically charged persons or objects may be hazardous to these components. In the worst case scenario, they will be destroyed immediately or will fail after start-up.
- Observe the requirements in accordance with DIN EN 61340-5-1 to minimize or avoid the possibility of damage caused by sudden electrostatic discharge!
- Also ensure that you do not touch electronic components when the supply voltage is on!

Deinstallation procedure:

- Switch the electrical power to the Control Unit - D4 off!
- Loosen the device (upper part) from the external position sensor (see “Fig. 11” on page 27).
- Open the housing following the instructions in chapter “6. Opening and Closing the Housing”.

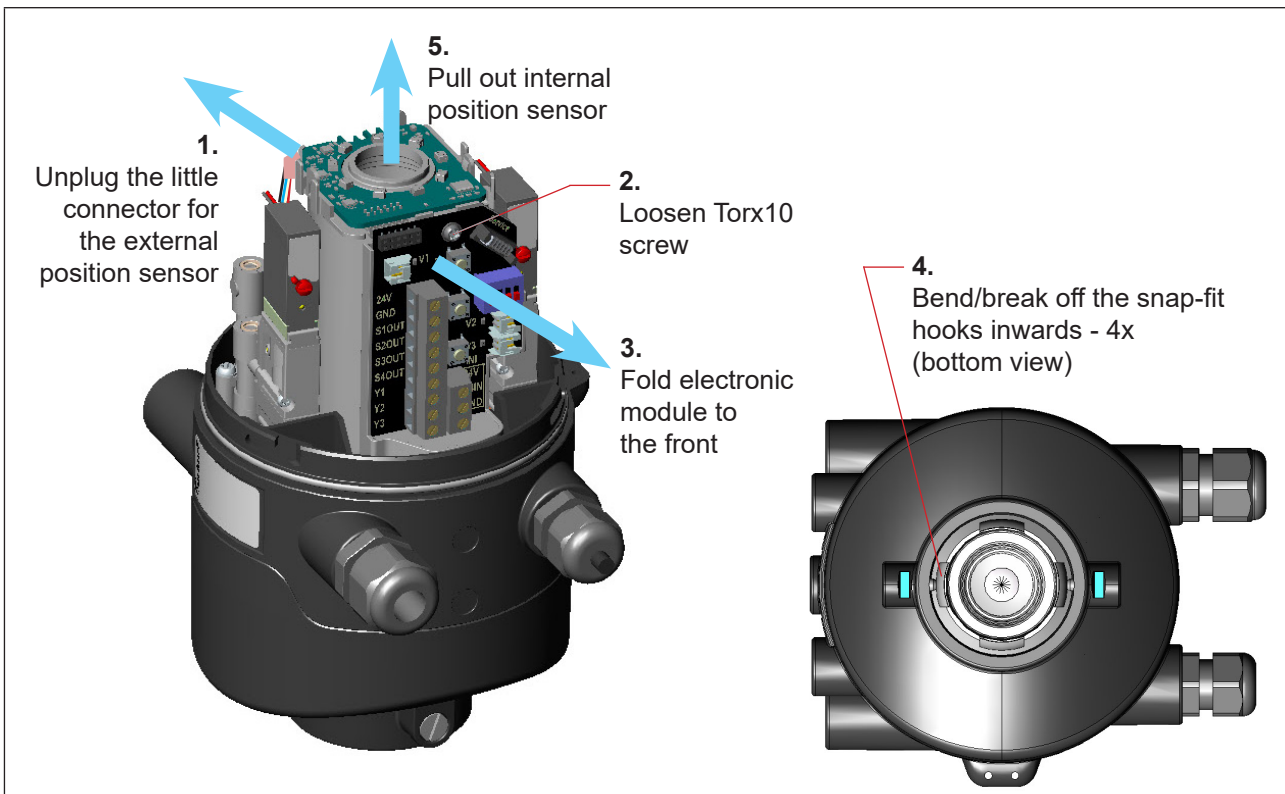

Fig. 40: Dismantling the internal position sensor



- (1) Unplug carefully the little 4-wire-connector for the external position sensor.
- (2) Loosen the fastening screw (Torx 10) of the electronic module (see chapter "[16.2. Changing the electronic module](#)").
- (3) Tilt the electronics forwards to loosen the internal position sensor's contact pins from the electronic module.
- (4) Bend the snap-fit hooks on the bottom end of the internal position sensor inwards or - in some cases - break them off.
- (5) Pull the internal position sensor upwards out of the guide.

Installation procedure:

- Insert the new internal position sensor from above so that the contact pins are located on the side of the electronic module.
- Carefully push the housing of the internal position sensor downwards until the snap-fit hooks snap into place.
- Slide the electronic module carefully onto the contacts pins and fasten the electronic module using the Torx screw.
- Plug the little 4-wire-connector for the external position sensor carefully into the little socket.
- Remount the device (upper part) to the external position sensor as described in chapter "[5. Assembly](#)".
- Adjust internal position sensor to the process valve via the Autotune function (see chapter "[12.2. Autotune function](#)")
- Close the housing following the instructions in chapter "[6. Opening and Closing the Housing](#)".

16.5. Spare parts

Order no.	Position number	Description
H342939	1	Control Unit 8681+ D4 (24 V design, 3 pilot valves)
H342940	1	Control Unit 8681+ D4 (AS-i design, 3 pilot valves)
H342941	1	Control Unit 8681+ D4 (DeviceNet design, 3 pilot valves)
H342943	1	Control Unit 8681+ D4 (24 V design, 1 pilot valve)
H342944	1	Control Unit 8681+ D4 (AS-i design, 1 pilot valve)
H342945	1	Control Unit 8681+ D4 (DeviceNet design, 1 pilot valve)
H342873	2	Pilot valve (Type 6524, solenoid valve module incl. flow restrictor module)
H342874	3	Cable with 12-pole plug M12, approx. 80 cm (for 24 V DC)
H342875	3	Cable with 4-pole plug M12, approx. 80 cm (for AS interface)
H342876	3	Cable with 5-pole plug M12, approx. 80 cm (for DeviceNet)
H342877	4	Cable complete for external position sensor
H342878	5	Hood, coated (SPX logo)
H342879	6	Set target for CU D4 (external + internal position sensor targets, shaft extension)
H342880	7	External position sensor (incl. 4 fixation screws M8, all O-rings, flat seal EPDM)
H342881	8	Flat seal EPDM (set of 20 pieces) - compare also "Fig. 12" on page 28
H342882	9	O-ring for hood (set of 50 pieces)
H342883	10	Silencer
H342884		Plombe twist seal (set of 20 pieces)

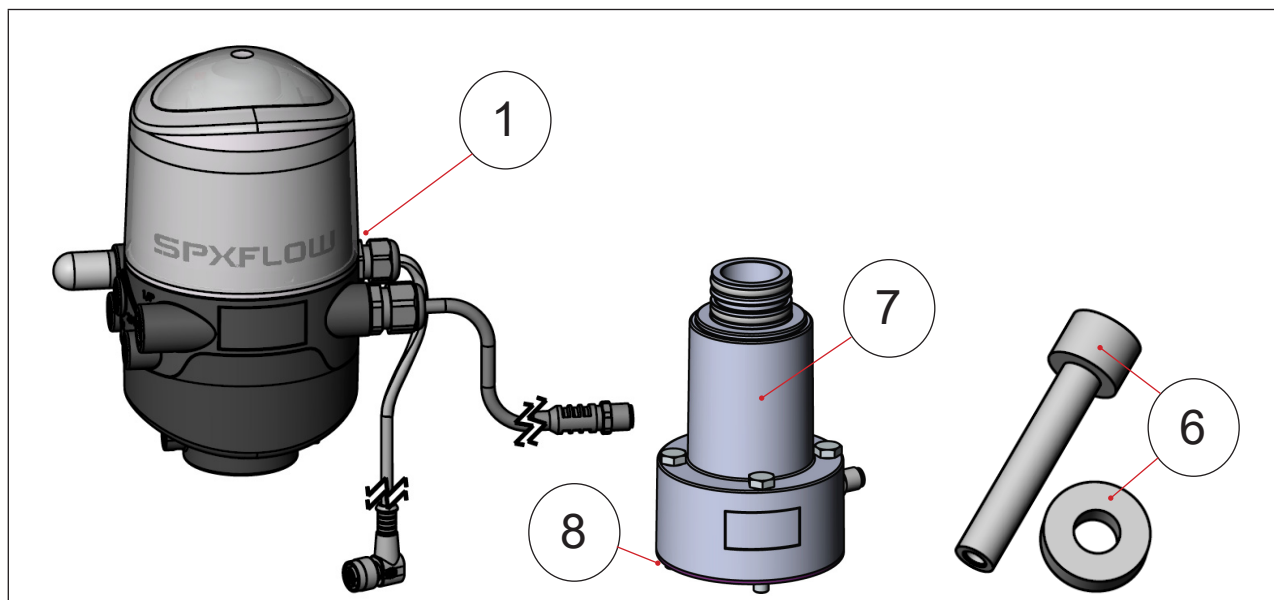

Fig. 41: Spare parts I

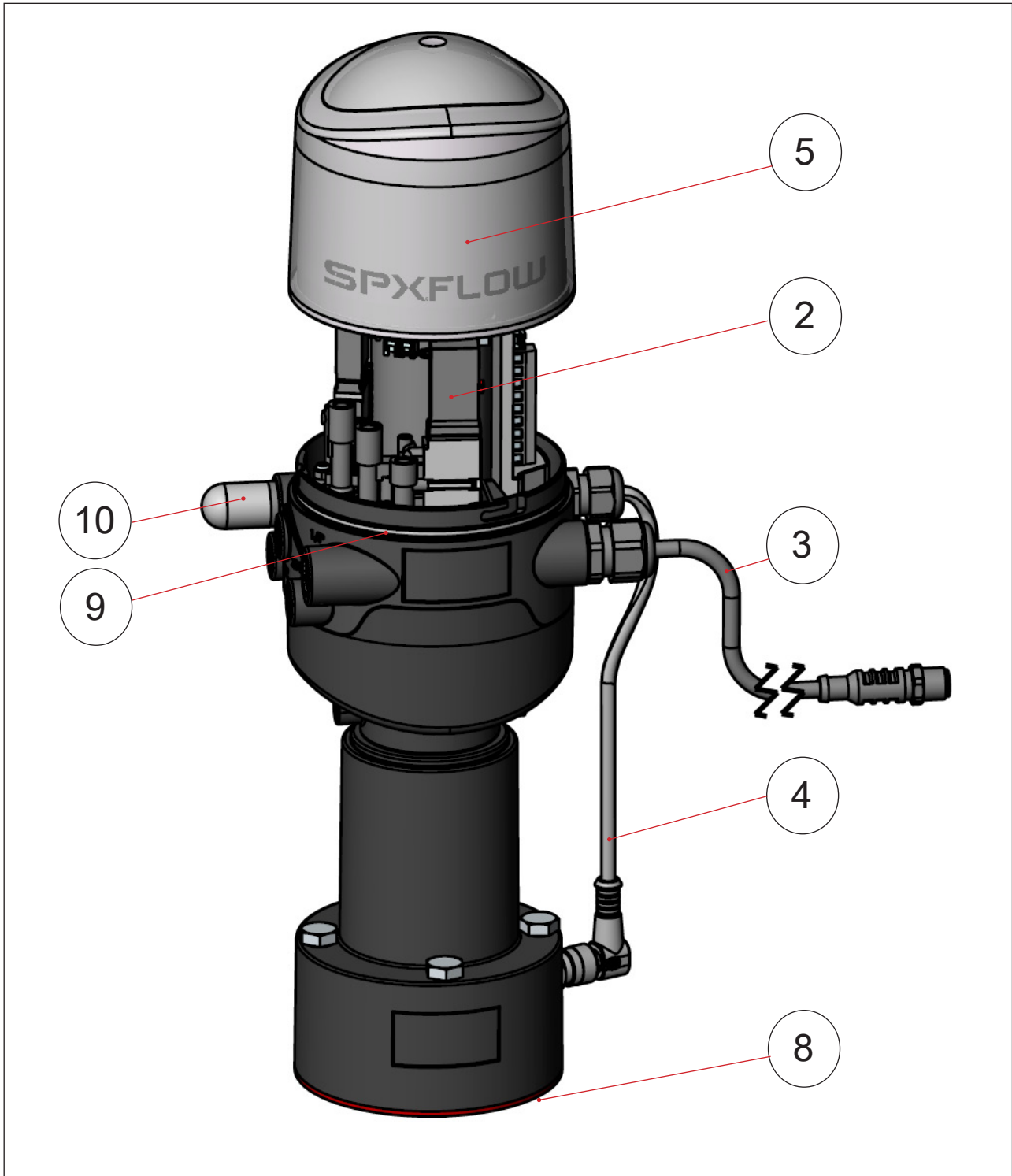

Fig. 42: Spare parts II

17. SHUTDOWN

17.1. Safety instructions



DANGER!

Risk of injury due to electric shock!

- ▶ Before reaching into the system, switch off the power supply and secure it to prevent restarting!
- ▶ Observe applicable accident prevention and safety regulations for electrical equipment!



WARNING!

Risk of injury due to high pressure!

- ▶ Before loosening lines and valves, turn off the pressure and vent the lines.

Risk of injury due to improper disassembly!

- ▶ Disassembly work may be carried out by trained technicians only and with the appropriate tools!

17.2. Dismantling the 8681 Control Unit - D4



Prior to starting with the work, check the system status!

Procedure:

- Remove the multi-pole plugs.
- Loosen the pneumatic connections (for a detailed description, see chapter [“7. Pneumatic Installation”](#)).
- Loosen the locking screws (2 x shoulder screws M5) to dismantle the control unit (upper part) only – or loosen the fixation screws (4 x M8) to dismantle the whole device.
- Pull the device upwards and off the adaptation, remove the flat seal.

18. PACKAGING AND TRANSPORT

NOTE!

Transport damage!

Inadequately protected devices may be damaged during transportation.

- ▶ During transportation protect the device against moisture and dirt in shock-resistant packaging.
- ▶ Avoid the effects of heat and cold which could result in temperatures above or below the permitted storage temperature.

Approved non-return and reusable transport containers are used for the transport ex factory and storage of the device. Preferably use this packaging.

If the device is stored for further pre-assembly of a system, for example as part of a process valve module, kindly make sure:

- that the device has been secured sufficiently!
- that the electrical and pneumatic lines cannot be accidentally damaged and / or cannot indirectly damage the device!
- that the device is not used as support during packaging and transport!
- that the device is not exposed to any mechanical stress!

19. STORAGE

NOTE!

Incorrect storage may damage the device.

- ▶ Store the device in a dry and dust-free location!
- Storage temperature: -20 ... +65 °C.

Kindly make sure that the devices, following storage at low temperatures, are heated slowly to room temperature before you carry out any assembly work on the devices or start operation of the devices!

20. DISPOSAL

→ Dispose of the device and packaging in an environmentally friendly manner.

NOTE!

Damage to the environment caused by device components contaminated with media.

- ▶ Observe the relevant disposal and environmental protection regulations.



Note:

Observe the national waste disposal regulations.



21. APPENDIX - EDS DESCRIPTION

Please refer to the following pages for the EDS description for devices with DeviceNet design .

Appendix - EDS description

ID (Param. in EDS file)	Class	In- stance	Attri- bute	Data type	Data size	Parameter description	Details	Default value	Reset to default by *)
1	150	1	5	USINT	1	Active input assembly	0 = Sensor state, valve state	0	
2	150	1	6	USINT	1	Safety mode	Bit 0: bus fault 0 = safety position (defined by class 150, instance 1, attribute 7). 1 = last valve position	0	
3	150	1	7	USINT	1	Process valve safety position	Maximum 1 pilot valve ON. 0 = all pilot valves V1, V2, V3 OFF 1 = pilot valve V1 ON, V2 and V3 OFF 2 = pilot valve V2 ON, V1 and V3 OFF 3 = pilot valve V3 ON, V1 and V2 OFF	0	
4	150	1	8	USINT	1	Teach function	Manual teach function. 0 = Don't teach 1 = Start Teach 1 (closed position) 2 = Start Teach 2 (open position) 3 = Start Teach 3 (upper seat lift) 4 = Start Teach 4 (lower seat lift)	0	
5	150	1	9	BYTE	1	Teach state	Bitcoded overview of teach positions: 0 = not taught, 1 = taught Bit0: closed position Bit1: open position Bit2: upper seat lift Bit3: lower seat lift	0	A, B
6	150	1	10	USINT	1	Teach Reset	Reset teach positions 1-4 0 = Don't reset / done 1 = Start reset	0	
	150	1	11	USINT	1	Device Reset	Reset selected device parameters. 0 = Don't reset / done. 1 = Start reset.	0	
	150	1	13	UDINT	4	ID 1 Device	Device identification number 1	99999999	
	150	1	14	UDINT	4	ID 1 Board	Board identification number 1	99999999	
	150	1	15	UDINT	4	ID 2 Device	Device identification number 2 (SPX H-number)	99999999	

*) Reset to default by: A = Factory reset | B = Device reset | C = Counter reset



Appendix - EDS description

ID (Param. in EDS file)	Class	In- stance	Attri- bute	Data type	Data size	Parameter description	Details	Default value	Reset to default by *)
12	150	1	16	UDINT	4	ID 2 Board	Board identification number 2	99999999	
13	150	1	17	UDINT	4	S/N Device	Serial number device	0	
14	150	1	18	UDINT	4	S/N Board	Serial number board	0	
15	150	1	19	DATE	2	Assembly date device	Assembly date device	0	
16	150	1	20	REAL	4	Firmware	Firmware version	0	
17	150	1	21	USINT	1	Autotune	Autotune 0 = Don't start / done. 1 = Start autotune	0	
19	150	1	23	USINT	1	Service indication Time	Service indication 0 = Disabled 1 = Enabled Activation / deactivation of service indication after expired time. If enabled, service indication via Top LED will be raised after time "Maintenance after days" (class 150, instance 1, attribute 39) expired. Expired time is counted by "Operating hours resettable" (class 150, instance 1, attribute 32).	0	A, B
20	150	1	24	USINT	1	Service indication Cycles	Service indication 0 = Disabled 1 = Enabled Activation / deactivation of service indication after expired pilot valve switching cycles V1, V2 or V3. If enabled, service indication via Top LED will be raised if at least one of the resettable switching cycle counter (V1 / V2 / V3: class 150, instance 1, attribute 34 / 36 / 38) exceeds its corresponding limit "Maintenance after cycles Vx" (V1 / V2 / V3: class 150, instance 1, attribute 40 / 41 / 42).	0	A, B
	150	1	25	USINT	1	TP1 positive	Feedback field range Teach Position 1 positive in 0.1 mm	10	A, B

*) Reset to default by: A = Factory reset | B = Device reset





Appendix - EDS description

ID (Param. in EDS file)	Class	In- stance	Attri- bute	Data type	Data size	Parameter description	Details	Default value	Reset to default by *)
22	150	1	26	USINT	1	TP1 negative	Feedback field range Teach Position 1 negative in 0.1 mm	10	A, B
23	150	1	27	USINT	1	TP2 positive	Feedback field range Teach Position 2 positive in 0.1 mm	10	A, B
24	150	1	28	USINT	1	TP2 negative	Feedback field range Teach Position 2 negative in 0.1 mm	10	A, B
25	150	1	29	USINT	1	TP3 positive	Feedback field range Teach Position 3 positive in 0.1 mm	10	A, B
26	150	1	30	USINT	1	TP3 negative	Feedback field range Teach Position 3 negative in 0.1 mm	10	A, B
27	150	1	50	USINT	1	TP4 positive	Feedback field range Teach Position 4 positive in 0.1 mm	10	A, B
28	150	1	51	USINT	1	TP4 negative	Feedback field range Teach Position 4 negative in 0.1 mm	30	A, B
29	150	1	31	UDINT	4	Operation hours total	Operation hours total	0	A
30	150	1	32	UDINT	4	Operation hours resettable	Operation hours resettable	0	A, B, C
31	150	1	33	UDINT	4	Cycles V1 total	Switching cycles V1 total	0	A
32	150	1	34	UDINT	4	Cycles V1 resettable	Switching cycles V1 resettable	0	A, B, C
33	150	1	35	UDINT	4	Cycles V2 total	Switching cycles V2 total	0	A
34	150	1	36	UDINT	4	Cycles V2 resettable	Switching cycles V2 resettable	0	A, B, C
35	150	1	37	UDINT	4	Cycles V3 total	Switching cycles V3 total	0	A
36	150	1	38	UDINT	4	Cycles V3 resettable	Switching cycles V3 resettable	0	A, B, C
	150	1	39	USINT	1	Maintenance after days	Limit for Service indication Time. Refer to class 150, instance 1, attribute 23.	365	A, B
	150	1	40	USINT	1	Maintenance after cycles V1 x1000	Switching cycles limit V1 for Service indication Cycles. Refer to class 150, instance 1, attribute 24.	10	A, B

*) Reset to default by: A = Factory reset | B = Device reset | C = Counter reset



Appendix - EDS description

ID (Param. in EDS file)	Class	In- stance	Attri- bute	Data type	Data size	Parameter description	Details	Default value	Reset to default by *)
39	150	1	41	USINT	1	Maintenance after cycles V2 x1000	Switching cycles limit V2 for Service indication Cycles. Refer to class 150, instance 1, attribute 24.	50	A, B
40	150	1	42	USINT	1	Maintenance after cycles V3 x1000	Switching cycles limit V3 for Service indication Cycles. Refer to class 150, instance 1, attribute 24.	50	A, B
41	150	1	43	USINT	1	Mode	Current device mode: 0 = Automatic mode 1 = Test mode 1 2 = Test mode 2 3 = Service mode (magnetic manual mode) (activated by magnetic manual control tool) 4 = Manual mode (PC Service Program) 5 = Autotune mode 6 = Reserved 7 = Device Reset mode	0	
43	150	1	47	BYTE	1	Counter Reset	Bitcoded reset of resettable operation hour and valve switching cycle counters: 0 = don't reset, 1 = reset Bit0: Operation hours resettable (Param 30) Bit1: Cycles V1 resettable (Param 32) Bit2: Cycles V2 resettable (Param 34) Bit3: Cycles V3 resettable (Param 36)	0	
44	150	1	48	USINT	1	Magnetic manual control active?	Magnetic manual control function active 0 = inactive 1 = active (can be used with magnetic manual control tool)	1	A, B

Reset to default by: A = Factory reset | B = Device reset | C = Counter reset



8681 Control Unit - D4

Control Unit for D4 series valves

SPXFLOW®

SPX FLOW

Design Center

Gottlieb-Daimler-Straße 13
D-59439 Holzwickede, Germany
P: (+49) (0) 2301-9186-0
F: (+49) (0) 2301-9186-300

SPX FLOW , Inc.

Production

611 Sugar Creek Road
Delavan, WI 53115, USA
P: (+1) 262 728 1900 or (800) 252 5200
F: (+1) 262 728 4904 or (800) 252 5012
E: wcb@spxflow.com

SPX FLOW

Production

Stanisława Jana Rolbieskiego 2
PL - 85-862 Bydgoszcz, Poland
P: (+48) 52 566 76 00
F: (+48) 52 525 99 09

SPX FLOW reserves the right to incorporate the latest design and material changes without notice or obligation.

Design features, materials of construction and dimensional data, as described in this manual, are provided for your information only and should not be relied upon unless confirmed in writing. Please contact your local sales representative for product availability in your region.

For more information visit www.spxflow.com.

The green ">" is a trademark of SPX FLOW, Inc.